

Pipemate – Introduction.....	4
If you have got deadlines to meet remember to name Pipemate.....	4
Pipemate – Your Pipeline to a Better World.....	4
How to Order.....	5
1. Product Type:.....	5
2. Sizes:.....	5
3. Quantity:.....	5
4. Coating:.....	5
5. Pipe Material:.....	5
6. Flange Specification:.....	5
7. Working/Test Pressure.....	5
8. Sealing Ring.....	5
Pipemate Concept.....	6
Basic Principle & Components.....	6
The Advantages and Limitations.....	8
The Pipemate Jointing System.....	10
Couplings are supplied without centre register as standard for all sizes.....	10
Material Specifications.....	13
End-flange, Centre Sleeve & Flange Body.....	13
Bolts, Studs and Nuts.....	13
Locating Plugs.....	13
Sealing Rings.....	13
Coating and Protection.....	13
For further information, please contact the Marketing Department.....	13
Corrosion Protection.....	13
Fusion Bonded Epoxy (FBEP) Coating.....	15
Technical and Physical Properties.....	16
Locating Plug.....	17
Engineering Data.....	18
A. Metal contact between pipes and sleeves.....	18
Total max. Deflection over the Coupling is $2x\alpha$	18
B. Pipe end move out of sleeve.....	18
Engineering Data.....	20
Typical Installation Instruction.....	21
The Installation of Pipemate Couplings.....	21
Typical Installation Instruction.....	23
The Installation of Pipemate Flange Adaptor.....	23
Typical Installation Instruction.....	25
Assembling the Coupling and Flange Adaptor.....	25
All dimensions are in mm unless otherwise stated.....	28
Pipemate Coupling.....	29
For M S Pipe to BS 534:1990,.....	29
BS 3600:1976; UPVC Pipe to BS 3505:1986.....	29
All dimensions are in mm unless otherwise stated.....	29
Pipemate Coupling.....	30
For Cast Iron Pipe to BS 78:1981 &.....	30

BS 1211:1981.....	30
All dimensions are in mm unless otherwise stated.....	30
Pipemate Coupling.....	31
For Asbestos Cement Pipe to BS486:1966.....	31
All dimensions are in mm unless otherwise stated.....	31
Pipemate Coupling.....	32
For UPVC Pipe to BS 3505: 1986.....	32
All dimensions are in mm unless otherwise stated.....	32
Pipemate Coupling.....	32
For UPVC Pipe to BS 5556:1978 (1986).....	32
All dimensions are in mm unless otherwise stated.....	32
Pipemate Coupling.....	33
For steel Pipe to JKR Standard.....	33
Notes: Length & Tolerance on pipe OD is to BS 534:1990.....	33
Pipemate Flange Adaptor.....	35
Advantages.....	35
Flange Specifications.....	35
Availability.....	35
Coating and Protection.....	35
The minimum radial contact dimension (c) should be 8mm.....	35
Reducing Flange Adaptor.....	36
Pipemate Flange Adaptor.....	38
For Ductile Iron Pipe to BS 4772:1988/ISO 2531:1991.....	38
Flange Drilled to PN10 & PN16.....	38
Pipemate Flange Adaptor.....	39
For M.S. Pipes to BS534:1990; BS 3600:1976;.....	39
UPVC Pipe to BS 3505:1986.....	39
Flange Drilled to PN10 & PN16.....	39
Pipemate Flange Adaptor.....	40
For Cast Iron Pipe to BS 78: 1981 and BS 1211: 1981.....	40
Flange Drilling to BS 10: 1962.....	40
Pipemate Flange Adaptor.....	41
For UPVC Pipe to BS 5556:1978 (1986).....	41
Flange Drilled to PN10 & PN16.....	41
Pipemate Flange Adaptor.....	42
For Steel Pipe to JKR Standard (Malaysia).....	42
Flange Drilled to PN10 & PN16.....	42
Notes: Length and Tolerance on pipes OD is to BS 534: 1990.....	42
Pipemate Stepped Coupling.....	44
Pipemate Stepped Coupling.....	44
To Connect Ductile Iron Pipe to Steel Pipe.....	44
Pipemate Stepped Coupling.....	46
To Connect Ductile Iron Pipe.....	46
To Asbestos Cement/Cast Iron Pipe.....	46
All dimensions are in mm unless otherwise stated.....	46
Pipemate Flange Restrained Dismantling Joint.....	47

The standard coating is Fusion Bonded Epoxy (FBEP)	47
Flange drilled to PN10, PN16 and PN25.....	49
Pipemate Flange Restrained Dismantling Joint.....	50
Flange drilled to PN10, PN16 and PN25	50
Flange Mating Dimensions.....	50
BS 10: 1962.....	50
ANSI B16.5: 1981	50
Flange Mating Dimensions.....	52
BS. 4504: Section 3.1: 1989	52
Flange Mating Dimensions.....	53
JIS B 2210 = 1984.....	53
DN: Nominal diameter	53

Pipemate – Introduction

Turning a pipedream into reality. Establishing a pipeline to progress. Pipemate is well-positioned to meet the demands of the pipeline industry.

We are here to fill the market's needs – with our range of quality couplings and flange adaptors.

Pipemate's expertise places the company in a position of knowledge and authority in industrial pipework. Fast, efficient service combined with superior products at the right market price is our philosophy.

Pipemate's pipe jointing system is also cost effective. That brings benefits and advantages to end users.

When you need to install pipelines carrying water, gas, oil, petrochemicals, sewage and solid material, come and talk to us about your pipe-jointing system needs.

If you have got deadlines to meet remember to name Pipemate.

Pipemate – Your Pipeline to a Better World.

How to Order

Pipemate is ready to deliver whatever you need, where you are and we make every effort to ensure that you receive the products you require quickly and accurately. Kindly provide the following information when ordering.

1. Product Type:

- a. Couplings – State whether with/without locating plug(s)
- b. Stepped Couplings
- c. Flange Adaptors
- d. Flange Restrained Dismantling Joints
- e. Blank Flange Adaptors
- f. Tee Couplings

2. Sizes:

Outside diameter of pipe, we make the product to fit the pipe.

3. Quantity:

The quantity dictates delivery, production and prices.

4. Coating:

Provide type of coating or finish required. Fusion Bonded Epoxy (FBEP), bituminous, Rilsan Nylon II, red primer, hot dipped galvanized or others.

5. Pipe Material:

Material of pipes (Cast Iron, Ductile Iron, Steel, UPVC etc.), class and wall thickness of pipes to be joined.

6. Flange Specification:

State flange drilling and flange nominal bore, provide the full specification and as many other details as possible.

7. Working/Test Pressure

What is the working and testing pressure of the pipeline. Whether underground or above ground application.

8. Sealing Ring

Type of material required e.g. NR, Nitrile, EPDM.

Pipemate Concept

Basic Principle & Components

Today, there are several methods of joining pipes, flexible compression type joints, o-ring joints, welding and flanging.

Pipemate couplings is manufactured to join most types of plain ended pipes and virtually plus rigid pipes and allows the pipe joint to be buried for many years service without any maintenance on the pipe joint itself.

Pipemate couplings are protected for life against corrosion with Fusion Bonded Epoxy Powder coatings.

Tighten a set of bolts by moving the two end flanges towards each other, compressing the wedge-shaped rubber sealing rings in the recesses between the centre sleeve and end flanges onto the pipe surface, forming and assuring an effective and long term leak proof joint.

Pipemate couplings are uniquely manufactured to assure a long term sealing performance without any additional maintenance after the initial installation.



END FLANGE



BOLT AND NUT

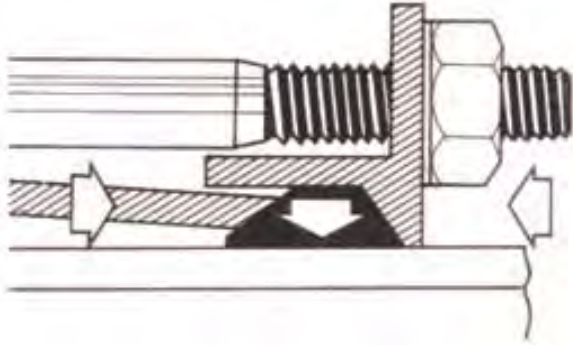

CENTRE SLEEVE



SEALING RING

The Advantages and Limitations

- The flexibility of the couplings easily takes care of axial expansion and contraction.
- Long radius curves slight bend can be laid without special bends.
- Our design assures you of good function under soil movement ground settlement and vibration.
- Accommodate deflection before, during or after installation and service.
- Accept minor misalignment in straight pipes and no expensive lining out of pipe-ends in the field is necessary.
- Easily take up normal laying tolerances. The couplings can be used to accommodate an extra big distance between pipe-ends.
- Pipemate couplings join pipe-ends without heat (welding) damage to the coating.
- No installation delays caused by adverse weather conditions.
- Coupling can be delivered with Fusion Bonded Epoxy Coating or Rilsan Nylon II – preventing corrosion or oxidation even under severe chemical attack, thus eliminating the need for sub-ground joint protection methods such as bituminous moulding, thermoplastic protective tape etc.
- All you need is a spanner. No welding equipment, on site joining equipment or generator is involved.
- Time saving installation eliminate the need for skilled labour.
- Minimum ground movement or excavation required for installation.
- Can be dismantled to enable quick repair or maintenance.
- Can join most rigid types of pipes and valves.

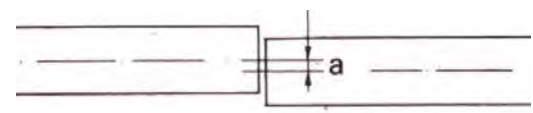
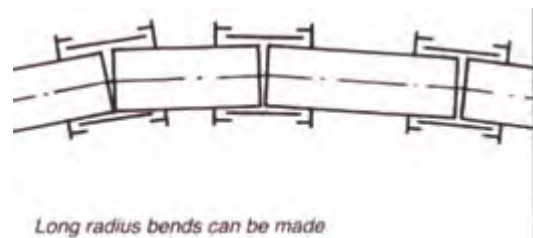
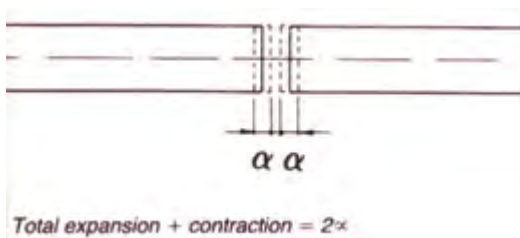

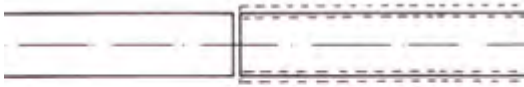

Absorpt vibration

Limitations:

Where pipe movement out of the coupling might occur, proper anchorage must be provided.

The Pipemate Jointing System

1. Coupling
Used for joining pipes of same or different materials and of similar pipe outside diameter.
2. Stepped Coupling
To connect pipes of same or different materials of different pipe outside diameter
3. Flange Adaptor
To join plain-ended pipes to any flanged fitting, flanged pipe and flanged valve.
4. Flange Restrained Dismantling Joint
To connect flanged valve to flanged pipe and must be installed above ground or in a chamber.
5. Blank Flange Adaptor
To connect plain ended pipes into a blank end or test end.
6. Tee Coupling
To make branch Tee connections to the pipe run.

Pipemate Coupling, Stepped Coupling, Flange Adaptor and Flange Restrained Dismantling Joints are manufactured from hot rolled steel plates and profiles, are available in the range 50mm to 2500mm nominal diameter.

Couplings are supplied without centre register as standard for all sizes.

Where Couplings that are installed above ground may move along the pipe, centre sleeves can be supplied with a screw-in (removable) locating plug.

To take up extra expansion and contraction an **Extra Long Sleeve** Coupling can be supplied.

It is most important to note that pipe specifications vary from country to country, however most pipe specifications will accommodate 'PIPEMATE' Couplings and Flange Adaptors.

Pipes furnished with plain-ends in accordance with B.S., A.W.W.A. and A.P.I. pipe specifications, will fit PIPEMATE Couplings and Flange Adaptors.

The DIN, however, specifies pipe diameter to a tolerance $\pm 1\%$ of the nominal pipe diameter. E.g. for a 914.4mm OD pipe, this means that the true OD may vary from 905.3mm to 923.5mm.

It is apparent that a standard Coupling is not designed for this tolerance field.



STRAIGHT COUPLING



FLANGE ADAPTOR



LONG SLEEVE COUPLING



FLANGE RESTRAINED DISMANTLING JOINT



LOCATING PLUG COUPLING



BLANK FLANGE ADAPTOR



STEPPED COUPLING



TEE COUPLING

Material Specifications

End-flange, Centre Sleeve & Flange Body

Rolled Steel to BS4360:1986 Grade 43

Bolts, Studs and Nuts

BS970: Part1:1983 Grade 070 M20 galvanized to BS3382 supplied as standard but HDG and stainless steel bolts and studs are available at extra cost. Fusion Bonded Epoxy Powder (FBEP) coated Couplings are supplied with FBEP Coated bolts and nuts.

Locating Plugs

Bronze supplied as standard, but also available in stainless steel at extra cost.

Sealing Rings

Natural Rubber (NR) to BS2494:1990 supplied as standard by EPDM, Nitrile and SBR to BS2494:1990 also available on request at extra cost.

Coating and Protection

The standard coating is Fusion Bonded Epoxy Powder (FBEP), an extremely effective anti-corrosion coating. Approx. 200 microns thick. Also available are Rilsan Nylon II, Hot Dip Galvanized (BS729), transit primer and two pack epoxy paint to meet customer requirements.

For further information, please contact the Marketing Department.

Corrosion Protection

In recent years there have been important developments in the concept of integral corrosion protection of pipes and pipe joints and this has become prevalent over the last few years.

Pipe and joint manufacturers have had to develop methods of coating their products at the point of manufacture rather than expect the contractor to make a totally effective job of protection on site, under frequently very difficult conditions.

Old established methods of corrosion protection such as hot poured bitumen are rapidly being superseded by a range of factory applied coatings in epoxy and nylon. It possesses a most satisfactory combination of physical properties giving bonding to the metal surface and excellent flexibility and scuff resistance to normal knocks and damages received during transit and handling.

The company's deep involvement with so many aspects of pipes and pipeline ensure constant feed back from the market's needs. This enables us to be innovative and far-sighted in products development and market trends.

The company's Fusion Bonded Epoxy Powder Coating plant, the country's fist, and another innovative move within the pipeline industry is installed at Serdang, Selangor Darul Ehsan.

Fusion Bonded Epoxy (FBEP) Coating

So, what's so good about Fusion Bonded Epoxy Coated Couplings and Flange Adaptors?

Couplings and Flange Adaptors are protected with Fusion Bonded Epoxy Powder Coatings which provide high quality protection. One coat application of 200 microns thick finish has an extremely strong bond with the metal surface and its gives superior long term corrosion protection. Ideally suited for pipe joints used for transmission of water, oil, gas and slurry.

- Corrosion protection
- Flexibility
- High mechanical strength
- Chemical resistant
- Abrasion resistant
- Cathodic disbanding resistant
- Temperature resistant

Fusion Bonded Epoxy Powder coatings provide high quality production to our products preventing corrosion of oxidation even under sever chemical attack thus eliminating the need for sub-ground joint protection methods such as bituminous moulding, thermoplastic protective tape and extrusion coating. The advantages of Fusion Bonded Epoxy Powder Coatings are; controlled plant operation, which permit high quality surface preparation and coating application, no interference with contraction progress because of poor weather condition, easier inspection and above all, superior long term corrosion protection.

Technical and Physical Properties

Surface preparation near-white blast as defined by SSPC-SPIO Swedish SA21/2. Film thickness approx. 200 microns.

	STANDARD	VALUE
Hardness	DIN 53153 ISO 2815	70 – 100+
Impact Resistance . (Direct)	Modified ASTM G-14-72	60 – 160 lbs.in
Pencilhardness	–	HB – 5H
Adhesion	DIN 53131 – 3mm ISO 2409 – 2mm	G10 – no loss of adhesion Approx. 31kg/mm ² (Break glue)
Tensile strength	ASTM D-2370-68	Approx. 500kg/cm ²
Elongation	ASTM D-2370-68	Approx. 6%
Salt spray	ASTM B 117-73	3000 hrs. no face rust 0-2mm creepage
Temperature stability	Dry heat	Excellent adhesion continuous exposure to 100°C
Water immersion	(a) ASTM D870 – 54 Distilled water 38°C (b) Tap water approx. 88°C	3000 hrs no blistering or other failure. 48 hrs no blistering or loss of adhesion.

Locating Plug

Couplings installed above ground may tend to creep along the pipe with repeated pipe movement. This can be restrained by using couplings fitted with a locating plug. Locating plugs can be of two type: (a) welded or (b) removable. In each case the plug will centre the coupling over the gap between pipes for ease of installation. However, make sure that enough clearance is obtained between pipe-ends and plug to allow for pipe expansion and deflection.

The replacement of a single section is difficult when welded plugs are used because more pipe sections and couplings have to be disassembled until the total clearance is enough to allow the centre sleeve to be taken out.

For this reason, the removable plug has been designed. After removal of the plugs the complete coupling can be moved backed along one pipe end to enable the other pipe to be taken out. The removable locating plugs may also be used for inspection of a proper installation.

Note: Location plugs are designed to prevent coupling movement rather than pipe movement.

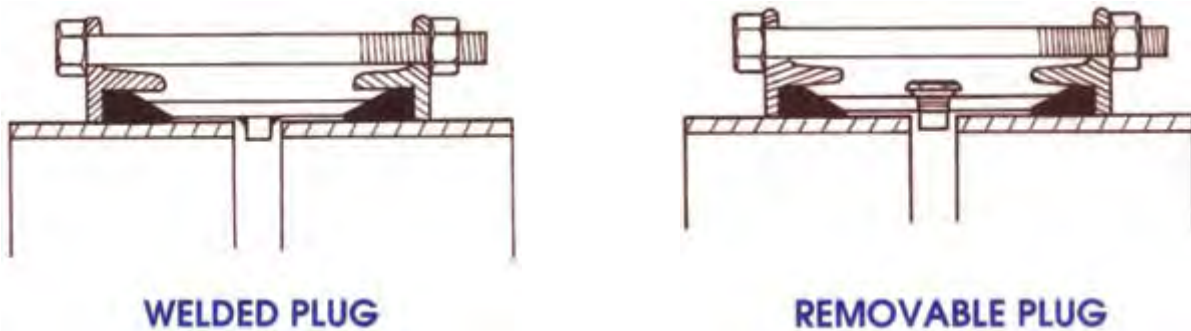

Expansion And Contraction

The Pipemate Coupling and Flange Adaptor is designed to absorb expansion and contraction between pipe ends to a certain extent. It is capable of accommodating repeated expansion and contraction between pipe ends and in fact this is achieved without sealing ring slippage on the pipe but by deformation of the sealing ring, permitting no leakage during pipe movement.

This movement is restricted to $\pm 2.5\text{mm}$ in and out per pipe end, making a maximum total movement (all sizes) of 10mm per Coupling and 5mm per Flange Adaptor.

Engineering Data

Angular Deflection

'PIPEMATE' Coupling and Flange Adaptor's allowable angular deflection of a pipe depends on several variables: -

- A. The length of the centre sleeve.
- B. The clearance between pipe OD and sleeve ID.
- C. The distance over which the pipe ends are inserted into the Coupling and Flange Adaptor (Setting Caps).

There are two limitations in calculating the maximum angular deflection. Either the pipe makes the metal contact with the sleeve (Fig1) or pipe ends moves too far to the end of the sleeve (Fig II). A safety of 25mm before the sealing ring recess should be kept.

The max. angle can be calculated as follows:-

A. Metal contact between pipes and sleeves

By deflection, metal to metal contact occurs between pipe and sleeve at Point 1 & 2 (see Fig I).

$$\operatorname{tg}\alpha = a/b$$

$$\operatorname{tg}\alpha = \frac{\text{Actual sleeve I.D.} - \text{actual p.o.d.}}{\frac{1}{2} (\text{sleeve length} - 2 \text{ sealing rings recess length})}$$

Total max. Deflection over the Coupling is $2x\alpha$.

B. Pipe end move out of sleeve

$$\operatorname{tg}\alpha = \frac{C}{\text{p.o.d.}}$$

$$\operatorname{tg}\alpha = \frac{\frac{1}{2} (\text{sleeve length} - 2 \text{ sealing rings recess length}) - 2x\alpha}{\text{p.o.d.}}$$

The min. distance between pipe end and sealing rings tip should be 25mm (=d). Total max. Deflection over the coupling is $2x\alpha$

Normally, calculation A is used for smaller pipe diameter, and calculation B is used for larger pipe diameter.

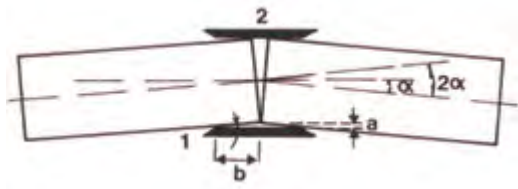

Fig I

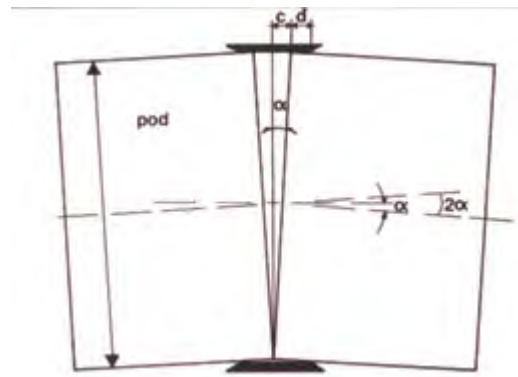

Fig II

Engineering Data

RECOMMENDED SETTING GAP TABLE				
Nominal Diameter	Coupling Sleeve Width	Recommended Setting Gap		Maximum Accumulated Gap
		Coupling	Flange Adaptor	
50 – 300mm	100mm	18mm	18mm	38mm
350 – 900mm	150mm	25mm	25mm	50mm
1000 – 1800mm	180mm	38mm	32mm	76mm
1800mm above	254mm	57mm	32mm	114mm

PIPE END PREPARATION TABLE		
Sleeve Length	Dimension L for Normal Coupling Assemble	Dimension for closing Connections
100mm	100mm	150mm
150mm	150mm	225mm
180mm	150mm	250mm
254mm	200mm	300mm

SETTING ANGULARITY TABLE		
Normal Diameter	Angle	Inclination
Coupling		
0 – 450mm	6.0°	1 in 10
500 – 600mm	5.0°	1 in 12
650 – 750mm	4.0°	1 in 15
800 – 1200mm	3.0°	1 in 20
1300 – 1800mm	2.0°	1 in 30
Over 1800mm	1.0°	1 in 60
Flange Adaptor		
100 – 450mm	3.0°	1 in 20
500 – 600mm	2.5°	1 in 24
650 – 750mm	2.0°	1 in 30
800 – 1200mm	1.5°	1 in 40
1300 – 1800mm	1.0°	1 in 60
Over 1800mm	0.5°	1 in 120

Typical Installation Instruction

The Installation of Pipemate Couplings

1. Check that pipe ends are circular and within specified tolerances. Clean each pipe end over a distance of 100 to 200mm back from the end. Be sure that pipe ends are smooth, free of damage, loose mill scale, oxides or roll damages, seams, bulges and if any, remove oil, dirt, loose scale and rust.
2. To aid centering of the Coupling over a pipe gap, mark pipe ends at a distance equal to half the width of the centre sleeve plus the width of one flange.
3. Slip end flanges over pipe ends and slide them back over cleaned area. Wipe gaskets clean and immerse in soapy water then stretch and slide them over each pipe end, thick end toward the end flange.
4. Clean centre sleeve, paying particular attention to flares on ends where gaskets will seat. Then insert centre sleeve onto pipe end already in position until centred. Bring up adjacent pipe and adjust setting gap, leaving a gap of 18mm to 57mm between pipe ends, to allow for movement occurrences, and to relieve the stresses of thermal movement. When a locating plug is used the setting gap should be increased by the plug thickness. The following setting gaps are suitable for general use but can be varied:
 - 18mm for sizes up to 300mm Ø
 - 25mm for sizes from 350 – 900mm Ø
 - 38mm for sizes from 1000 – 1800mm Ø
 - 57mm for sizes above 1800mm Ø
5. Slide gaskets into position, making sure gaskets are pushed under the centre sleeve flare all the way round.
6. Centred end flanges bolt holes. Insert bolts. Every other bolt shall be installed with nuts facing opposite directions. Fit nuts finger tight.
7. Tighten Bolts & Nuts gradually with a Torque wrench diametrically opposed bolts. Do this in successive stages, two or three turns at a time, to draw the end flanges up evenly, working around the Couplings as necessary until all bolts have a uniform required torque. (refer to Fig III)

Recommended torques:

½" Bolt – 50 to 65 Nm (40 to 50 lb ft)

5/8" Bolt – 95 to 120Nm (70 to 90lb ft)

Tolerances:

The outside diameter over the length "L" must be within the specified tolerance as stated in the schedule of dimensions, if pressure ratings are to be maintained. Within the areas of the seal (Length 'L') pipe surfaces should be clean, even and smooth, without pitting, flat spots, weld beads or other overdressing.

8. On completion of tightening check that gap between the pipe body and the end flange is even all round, with gasket extruded into gap.

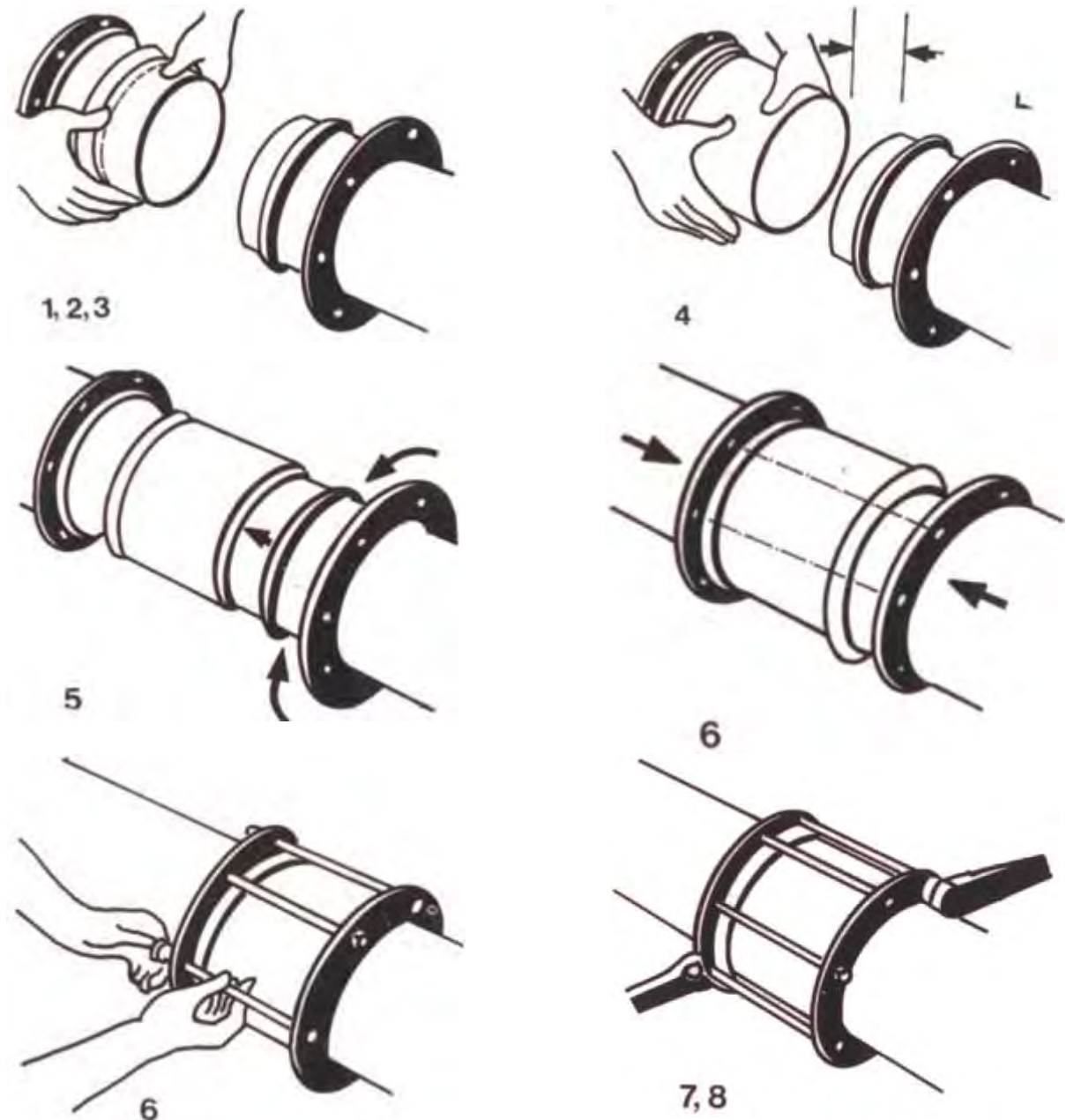

Typical Installation Instruction

The Installation of Pipemate Flange Adaptor

1. Check that pipe ends are circular and within specified tolerances. Clean each pipe end over a distance of 100 to 200mm back from the end. Be sure that pipe ends are smooth, free from damage, loose mill scale, oxides or roll damages, seams, bulges and if any, to remove oil, dirt, loose scale and rust.
2. Slip end flange over pipe end and slide them back over clean area. Wipe gaskets clean and immerse in soapy water then stretch and slide them over pipe end, thick end toward the end flange.
3. Clean adaptor body, paying particular attention to flares on ends where gasket will seat. Then insert adaptor sleeve onto pipe end. Ensure pipe end is concentric with mating flange. Adjusting setting gap, leaving a gap of 18mm to 32 mm between pipe end and mating flange, to allow for movement occurrences, and to relieve the stresses of thermal movements. The following recommended setting gap are suitable for general use but can be varied:
 - 18mm for sizes up to 300mm Ø
 - 25mm for sizes from 350 – 900mm Ø
 - 32mm for sizes over 900mm Ø
4. Fit flange gasket, line up bolt holes. Bolt up adaptor to mating flange using standard procedure.
5. Slide gasket into position making sure gasket is pushed under Adaptor body flare all the way around. Push end flange into position and locate studs. Fit nuts finger tight.
6. Tighten nuts gradually with a torque wrench diametrically opposed bolts, a little at a time, to draw the end flange up evenly. Working around the adaptor as many times as necessary until all bolts have a uniform required torque. (refer to Figure III)

Recommended torques:

½" Bolt – 50 to 65 Nm (40 to 50 lb ft)

5/8" Bolt – 95 to 120Nm (70 to 90lb ft)

7. On completion of tightening, check that the gap between pipe body and end flange is even all round, with gasket extruded into gap.

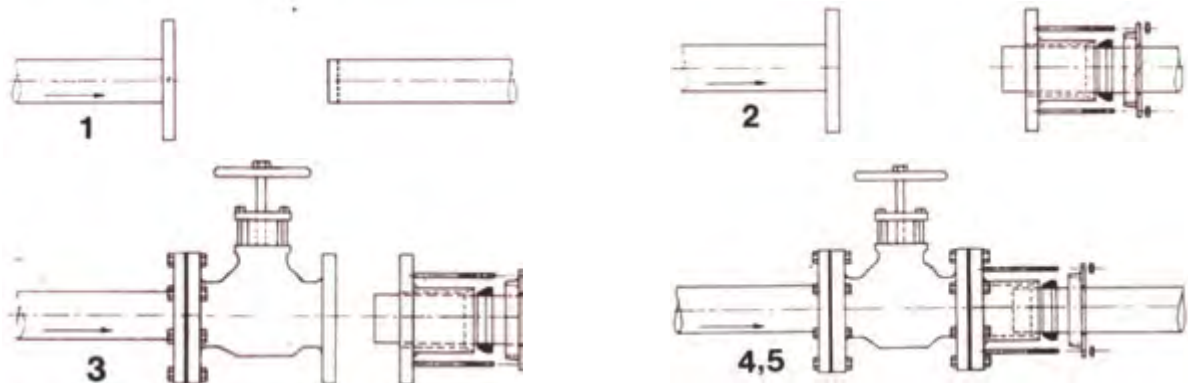

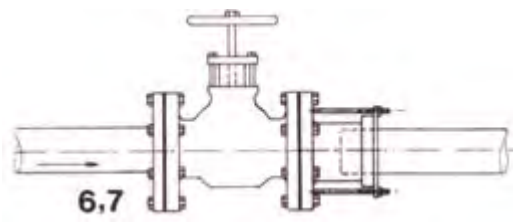

Typical Installation Instruction

Assembling the Coupling and Flange Adaptor

Tighten the bolts/studs and nuts gradually with a wrench (torque wrench is recommended) in successive stages two or three turns a time, or diametrically opposed bolts/studs, to draw the flange up evenly in the sequence of the numbers shown in the given diagram as an example.

The recommended torques shall be as follows:

1/2" Bolt – 50 to 65 Nm

5/8" Bolt – 95 to 120Nm

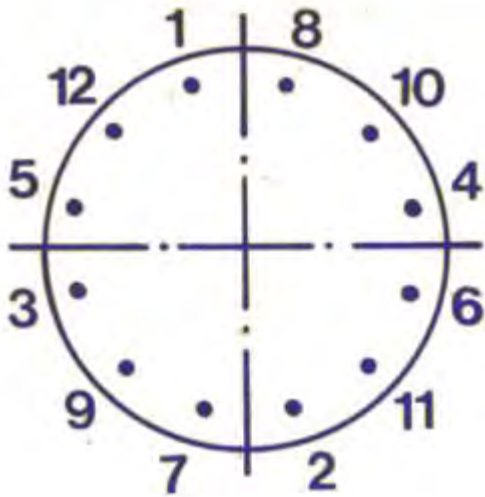
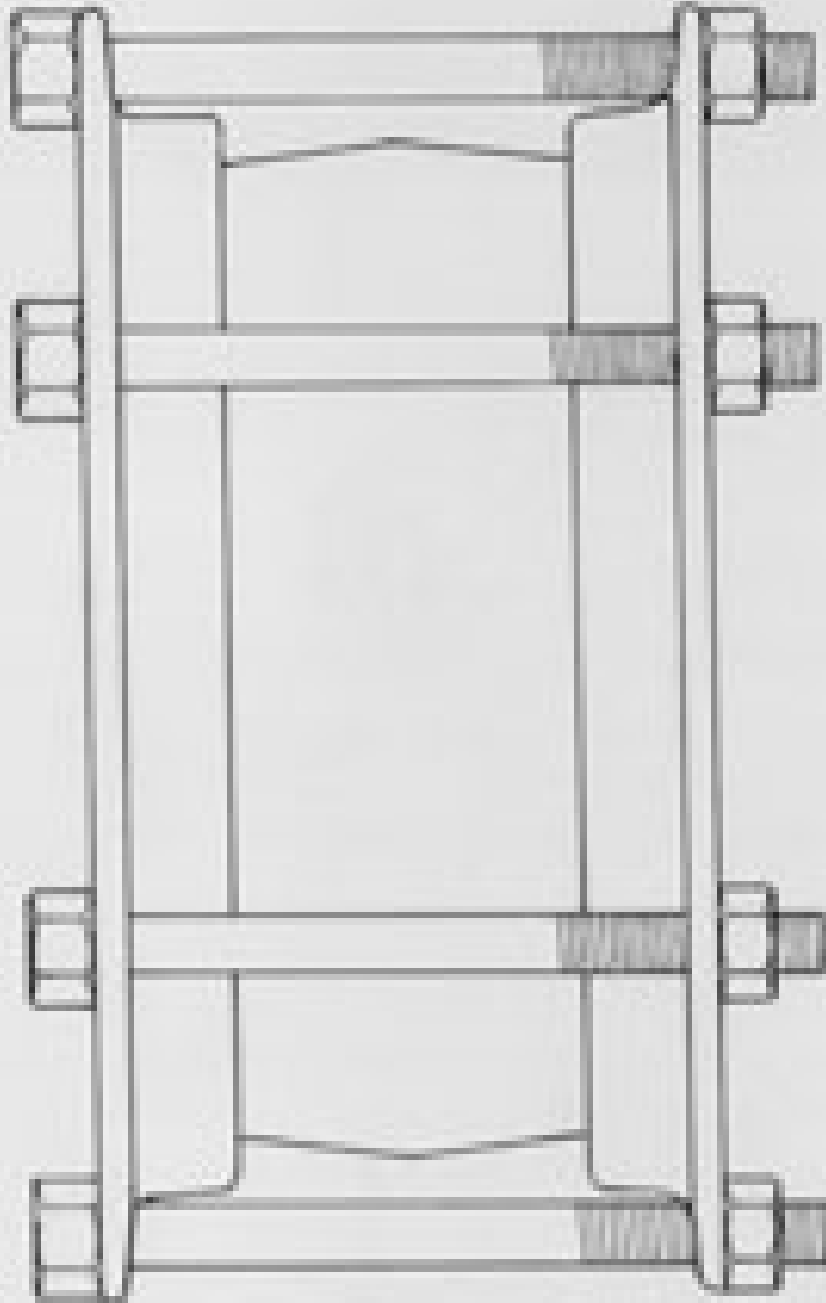
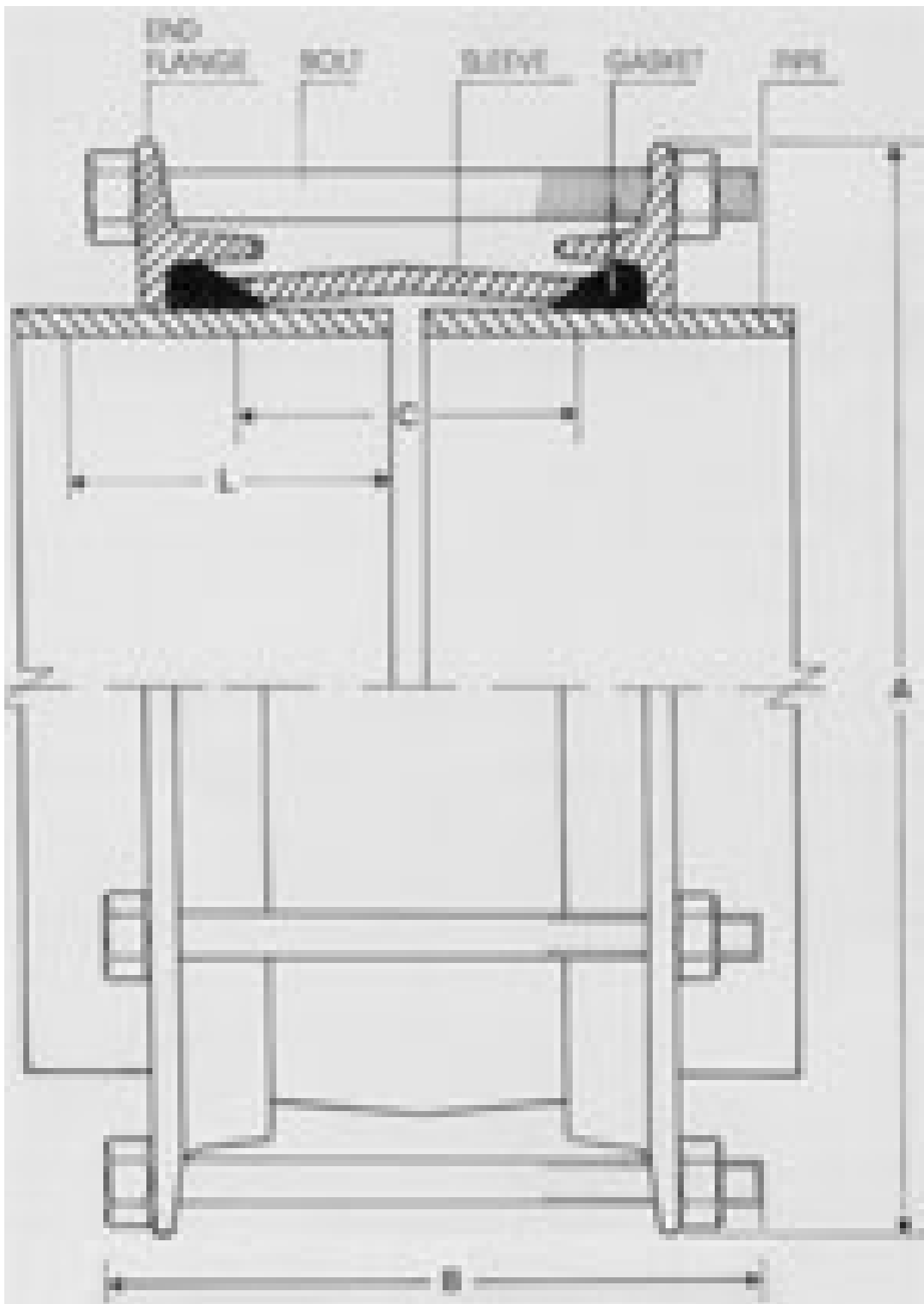

Figure III

PIPEMATE COUPLING





**Pipemate Coupling
for Ductile Iron Pipe to BS 4772:1988; ISO 2531:1991
Cast Iron Pipe to BS 4622**

All dimensions are in mm unless otherwise stated.

Pipe Dimensions			Coupling Dimensions					
Nom. Bore	Pipe OD	Tol on OD for light L	L	A	B	Sleeve C x Av thickness	No.	Bolts Dia x lgth
80	98	+1.0 -3.0	100	198	175	100 x 6	4	1/2" x 6 1/2"
100	118	+1.0 -3.0	100	220	175	100 x 6	4	1/2" x 6 1/2"
150	170	+1.0 -3.0	100	272	175	100 x 7	4	1/2" x 6 1/2"
200	222	+1.0 -3.5	100	326	175	100 x 8	5	1/2" x 6 1/2"
250	274	+1.0 -3.5	100	379	175	100 x 8	6	1/2" x 6 1/2"
300	326	+1.0 -3.5	100	430	175	100 x 8	6	1/2" x 6 1/2"
350	378	+1.0 -3.5	150	482	228	150 x 8	8	1/2" x 8 1/2"
400	429	+1.0 -4.0	150	532	228	150 x 8	8	1/2" x 8 1/2"
450	480	+1.0 -4.0	150	584	228	150 x 8	8	1/2" x 8 1/2"
500	532	+1.0 -4.0	150	636	228	150 x 8	10	1/2" x 8 1/2"
600	635	+1.0 -4.5	150	738	228	150 x 8	12	1/2" x 8 1/2"
700	738	+1.0 -4.5	150	842	228	150 x 8	12	1/2" x 8 1/2"
800	842	+1.0 -4.5	150	946	228	150 x 8	14	1/2" x 8 1/2"
900	945	+1.0 -5.0	150	1050	266	180 x 9	14	1/2" x 10"
1000	1048	+1.0 -5.0	150	1156	266	180 x 9	14	1/2" x 10"
1100	1152	+1.0 -6.0	150	1276	280	180 x 12	16	1/2" x 10 1/2"
1200	1255	+1.0 -6.0	150	1380	280	180 x 12	18	1/2" x 10 1/2"
1400	1462	+1.0 -7.0	150	1586	280	180 x 12	20	1/2" x 10 1/2"
1600	1668	+1.0 -8.0	150	1792	280	180 x 12	24	1/2" x 10 1/2"
1800	1875	+1.0 -8.0	200	2010	370	254 x 15	32	1/2" x 14"
2000	2082	+1.0 -8.0	200	2217	370	254 x 15	36	1/2" x 14"

These sizes are indications, Coupling for other pipe sizes and pressures are available on request. Sizes are approximate and can be modified without prior notice.

Pipemate Coupling
For M S Pipe to BS 534:1990,
BS 3600:1976; UPVC Pipe to BS 3505:1986.

All dimensions are in mm unless otherwise stated.

Pipe Dimensions			Coupling Dimensions					
Nom. Bore	Pipe OD	Tol on OD for light L	L	A	B	Sleeve C x Av thickness	Bolts No.	Bolts Dia x lgth
80	88.9	±0.8	100	190	175	100 x 6	4	½" x 6½"
100	114.3	±0.8	100	218	175	100 x 6	4	½" x 6½"
150	168.3	+1.6 -0.8	100	270	175	100 x 7	4	½" x 6½"
200	219.1	+1.6 -0.8	100	324	175	100 x 8	5	½" x 6½"
250	273.0	+1.6 -0.8	100	377	175	100 x 8	6	½" x 6½"
300	323.9	+1.6 -0.8	100	426	175	100 x 8	6	½" x 6½"
350	355.6	±1.6	150	460	228	150 x 8	6	¾" x 8½"
400	406.4	±1.6	150	510	228	150 x 8	8	¾" x 8½"
450	457.0	±1.6	150	562	228	150 x 8	8	¾" x 8½"
500	508.0	±1.6	150	612	228	150 x 8	8	¾" x 8½"
550	559.0	±1.6	150	664	228	150 x 8	10	¾" x 8½"
600	610.0	±1.6	150	716	228	150 x 9	10	¾" x 8½"
650	660.0	±1.6	150	766	228	150 x 8	12	¾" x 8½"
700	711.0	±1.6	150	817	228	150 x 8	12	¾" x 8½"
750	762.0	±1.6	150	868	228	150 x 8	12	¾" x 8½"
800	813.0	±1.6	150	920	228	150 x 8	14	¾" x 8½"
850	864.0	±1.6	150	970	228	150 x 8	14	¾" x 8½"
900	914.0	±1.6	150	1020	266	180 x 9	14	¾" x 10"
1000	1016.0	±1.6	150	1126	266	180 x 9	14	¾" x 10"
1200	1220.0	±1.6	150	1346	280	180 x 12	18	¾" x 10½"
1400	1420.0	±1.6	150	1546	280	180 x 12	20	¾" x 10½"
1600	1620.0	±3.0	150	1746	280	180 x 12	24	¾" x 10½"
1800	1820.0	±3.0	150	1946	280	180 x 12	28	¾" x 10½"
2000	2020.0	±3.0	200	2155	370	254 x 15	36	¾" x 14"
2100	2134.0	±3.0	200	2269	370	254 x 15	36	¾" x 14"
2200	2220.0	±3.0	200	2355	370	254 x 15	40	¾" x 14"

Pipemate Coupling
For Cast Iron Pipe to BS 78:1981 &
BS 1211:1981

All dimensions are in mm unless otherwise stated.

Pipe Dimensions			Coupling Dimensions						
Nom. Bore	Pipe OD	Class	Tol on OD for light L	L	A	B	Sleeve C x Av thickness	Bolts No.	Bolts Dia x lgth
3"	3.76"	ABCD	±2.0	100	196	175	100 x 6	4	½" x 6½"
4"	4.80"	ABCD	±2.0	100	224	175	100 x 6	4	½" x 6½"
5"	5.90"	ABCD	±2.0	100	250	175	100 x 7	4	½" x 6½"
6"	6.98"	ABCD	±2.0	100	280	175	100 x 7	4	½" x 6½"
7"	8.06"	ABCD	±2.0	100	305	175	100 x 7	4	½" x 6½"
8"	9.14"	ABCD	±2.0	100	336	175	100 x 8	5	½" x 6½"
9"	10.20"	ABCD	±2.0	100	360	175	100 x 8	6	½" x 6½"
10"	11.26"	ABCD	±2.0	100	390	175	100 x 8	6	½" x 6½"
12"	13.14"	AB	±2.0	100	434	175	100 x 8	6	½" x 6½"
12"	13.60"	CD	±2.0	100	448	175	100 x 8	6	½" x 6½"
14"	15.22"	AB	±2.0	150	490	228	150 x 8	8	¾" x 8½"
14"	15.72"	CD	±2.0	150	502	228	150 x 8	8	¾" x 8½"
15"	16.26"	AB	±2.0	150	516	228	150 x 8	8	¾" x 8½"
15"	16.78"	CD	±2.0	150	530	228	150 x 8	8	¾" x 8½"
16"	17.30"	AB	±2.0	150	542	228	150 x 8	8	¾" x 8½"
16"	17.84"	CD	±2.0	150	558	228	150 x 8	8	¾" x 8½"
18"	19.38"	AB	±2.0	150	596	228	150 x 8	8	¾" x 8½"
18"	19.96"	CD	±2.0	150	612	228	150 x 8	10	¾" x 8½"
20"	21.46"	AB	±2.0	150	650	228	150 x 8	10	¾" x 8½"
20"	22.06"	CD	±2.0	150	664	228	150 x 8	10	¾" x 8½"
21"	22.50"	AB	±2.0	150	676	228	150 x 8	10	¾" x 8½"
21"	23.12"	CD	±2.0	150	693	228	150 x 8	10	¾" x 8½"
24"	25.60"	AB	±2.0	150	756	228	150 x 8	12	¾" x 8½"
24"	26.26"	CD	±2.0	150	772	228	150 x 8	12	¾" x 8½"
27"	28.70"	AB	±2.0	150	833	228	150 x 8	12	¾" x 8½"
27"	29.40"	CD	±2.0	150	851	228	150 x 8	12	¾" x 8½"
30"	31.78"	AB	±2.0	150	913	228	150 x 8	14	¾" x 8½"
30"	32.53"	CD	±2.0	150	931	228	150 x 8	14	¾" x 8½"
33"	34.88"	AB	±2.0	200	992	266	180 x 9	14	¾" x 10"
33"	35.66"	CD	±2.0	200	1012	266	180 x 9	14	¾" x 10"
36"	37.96"	AB	±2.0	200	1070	266	180 x 9	14	¾" x 10"
36"	38.76"	CD	±2.0	200	1090	266	180 x 9	14	¾" x 10"

Pipemate Coupling For Asbestos Cement Pipe to BS486:1966

All dimensions are in mm unless otherwise stated.

Pipe Dimensions			Coupling Dimensions					
Nom. Bore	Pipe OD	Tol on OD for lght L	L	A	B	Sleeve C x Av thkness	Bolts No.	Bolts Dia x lgth
3"	96	±1.6	100	196	175	100 x 6	4	½" x 6½"
4"	122	±1.6	100	224	175	100 x 6	4	½" x 6½"
6"	178	±1.6	100	280	175	100 x 7	4	½" x 6½"
8"	232	±1.6	100	336	175	100 x 8	5	½" x 6½"
9"	259	±1.6	100	360	175	100 x 8	6	½" x 6½"
10"	286	±1.6	100	390	175	100 x 8	6	½" x 6½"
12"	334	±1.6	100	434	175	100 x 8	6	½" x 6½"
12"	345	±1.6	100	448	175	100 x 8	6	½" x 6½"
15"	413	±1.6	150	516	228	150 x 8	8	⅝" x 8½"
15"	426	±1.6	150	530	228	150 x 8	8	⅝" x 8½"
18"	492	±1.6	150	596	228	150 x 8	8	⅝" x 8½"
18"	507	±1.6	150	612	228	150 x 8	10	⅝" x 8½"
21"	571	±1.6	150	676	228	150 x 8	10	⅝" x 8½"
21"	587	±1.6	150	693	228	150 x 8	10	⅝" x 8½"
24"	650	±1.6	150	756	228	150 x 8	12	⅝" x 8½"
24"	667	±1.6	150	772	228	150 x 8	12	⅝" x 8½"

**Pipemate Coupling
For UPVC Pipe to BS 3505: 1986**

All dimensions are in mm unless otherwise stated.

Pipe Dimensions			Coupling Dimensions					
Nom. Bore	Pipe OD	Tol on OD for lght L	L	A	B	Sleeve C x Av thkness	Bolts No.	Bolts Dia x lgth
100	114,1	±0.8	100	218	175	100 x 6	4	½" x 6½"
155	168.0	+1.6 -0.8	100	270	175	100 x 7	4	½" x 6½"
200	218.8	+1.6 -0.8	100	324	175	100 x 8	5	½" x 6½"
250	272.6	+1.6 -0.8	100	375	175	100 x 8	6	½" x 6½"

**Pipemate Coupling
For UPVC Pipe to BS 5556:1978 (1986)**

All dimensions are in mm unless otherwise stated.

Pipe Dimensions			Coupling Dimensions					
Nom. Bore	Pipe OD	Tol on OD for lght L	L	A	B	Sleeve C x Av thkness	Bolts No.	Bolts Dia x lgth
63	63	+0.3 -0	100	163	175	100 x 6	2	½" x 6½"
75	75	+0.3 -0	100	175	175	100 x 6	2	½" x 6½"
90	90	+0.3 -0	100	190	175	100 x 6	4	½" x 6½"
110	110	+0.4 -0	100	212	175	100 x 6	4	½" x 6½"
125	125	+0.4 -0	100	227	175	100 x 7	4	½" x 6½"
140	140	+0.5 -0	100	242	175	100 x 7	4	½" x 6½"
160	160	+0.5 -0	100	264	175	100 x 7	4	½" x 6½"
180	180	+0.6 -0	100	284	175	100 x 7	4	½" x 6½"
200	200	+0.6 -0	100	304	175	100 x 8	4	½" x 6½"
225	225	+0.7 -0	100	329	175	100 x 8	5	½" x 6½"
250	250	+0.8 -0	100	354	175	100 x 8	6	½" x 6½"
280	280	+0.9 -0	100	384	175	100 x 8	6	½" x 6½"
315	315	+1.0 -0	100	419	175	100 x 8	6	½" x 6½"
355	355	+1.1 -0	150	459	228	150 x 8	6	¾" x 8½"
400	400	+1.2 -0	150	504	228	150 x 8	8	¾" x 8½"
450	450	+1.4 -0	150	554	228	150 x 8	8	¾" x 8½"
500	500	+1.5 -0	150	604	228	150 x 8	8	¾" x 8½"

Pipemate Coupling
For steel Pipe to JKR Standard
(Malaysia)

Notes: Length & Tolerance on pipe OD is to BS 534:1990
 All dimensions are in mm unless otherwise stated.

Pipe Dimensions			Coupling Dimensions					
Nom. Bore	Pipe OD	Tol on OD for lght L	L	A	B	Sleeve C x Av thkness	Bolts No.	Bolts Dia x lgth
100	121.9	±0.8	100	224	175	100 x 6	4	½" x 6½"
150	177.3	+1.6 -0.8	100	280	175	100 x 7	4	½" x 6½"
200	232.2	+1.6 -0.8	100	336	175	100 x 8	5	½" x 6½"
250	286	+1.6 -0.8	100	390	175	100 x 8	6	½" x 6½"
300	345.4	+1.6 -0.8	100	448	175	100 x 8	6	½" x 6½"
350	399.3	±1.6	150	499	228	150 x 8	8	¾" x 8½"
400	453.1	±1.6	150	558	228	150 x 8	8	¾" x 8½"
450	507	±1.6	150	612	228	150 x 8	8	¾" x 8½"
500	560.3	±1.6	150	665	228	150 x 8	10	¾" x 8½"
600	667	±1.6	150	772	228	150 x 8	12	¾" x 8½"
650	692	±1.6	150	796	228	150 x 8	12	¾" x 8½"
700	754	±1.6	150	858	228	150 x 8	12	¾" x 8½"
750	804	±1.6	150	908	228	150 x 8	12	¾" x 8½"
800	854	±1.6	150	958	228	150 x 8	14	¾" x 8½"
850	904	±1.6	150	1008	228	150 x 8	14	¾" x 8½"
900	954	±1.6	150	1058	266	180 x 8	14	¾" x 10"

PIPEMATE FLANGE ADAPTOR

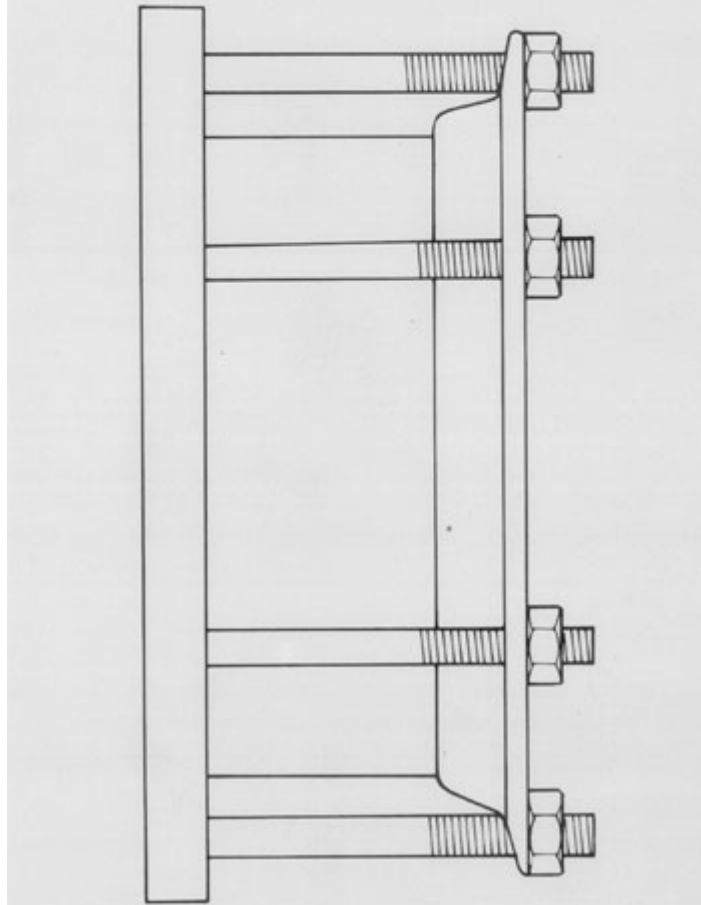

Pipemate Flange Adaptor

The Pipemate Flange Adaptor offers the same advantages of the Pipemate Coupling plus additional benefits. It is the most ideal solution for connecting flanged pipes, flanged specials, flanged valves and flanged pumps in any piping system.

Advantages

- No welding required.
- Flanged specials such as valves can be installed in any position.
- Any flange specification can be used.
- Available with factory applied quality coatings such as FBEP and Rilsan Nylon II.
- Eliminating costly downtime for repair.
- Can be installed quickly and easily.

Flange Specifications

- Adaptors are supplied standard with flat faces. These are suitable for bolting to raised faces. Raised face on request at extra cost.
- Flange drilling can be made according to various international standards and specifications.

Availability

- Available in mild steel as standard in the range of 50mm to 2500mm nominal diameter. Larger sizes available on request.
- Can be supplied for all pipe diameters and pipe materials.
- Fixed Galvanized Mild Steel stud bolts are supplied standard. FBEP coated stud bolts are supplied as standard for all FBEP Coated Flange Adaptors. Hot Dip Galvanized, Stainless Steel studs are also available on request at extra cost.

Coating and Protection

- The standard coating is Fusion Bonded Epoxy Powder (FBEP), an extremely effective anti-corrosion coating. Approx. 200 microns thick. Also available are Rilsan Nylon II, Hot Dip Galvanized, Transit Primer and Two Pack Epoxy Paint to meet customer requirements.

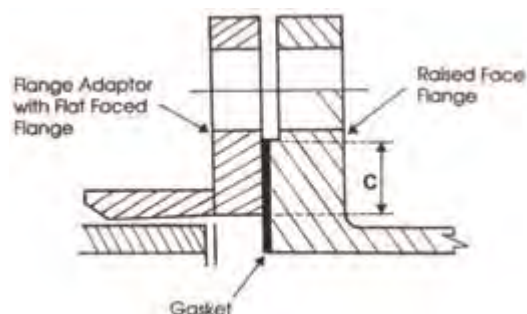

The minimum radial contact dimension (c) should be 8mm.

Reducing Flange Adaptor

We offers these specifically for use when connecting a flange with a different nominal bore of the pipe. (e.g. Connecting 16" nom. Pipe to a 14" nom. valve) and where the flange drilling does not correspond with the outside diameter of the pipe.

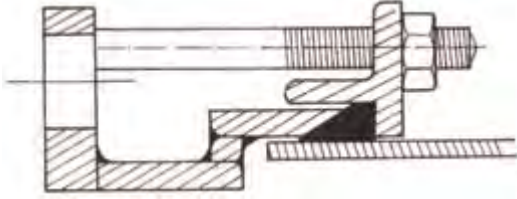

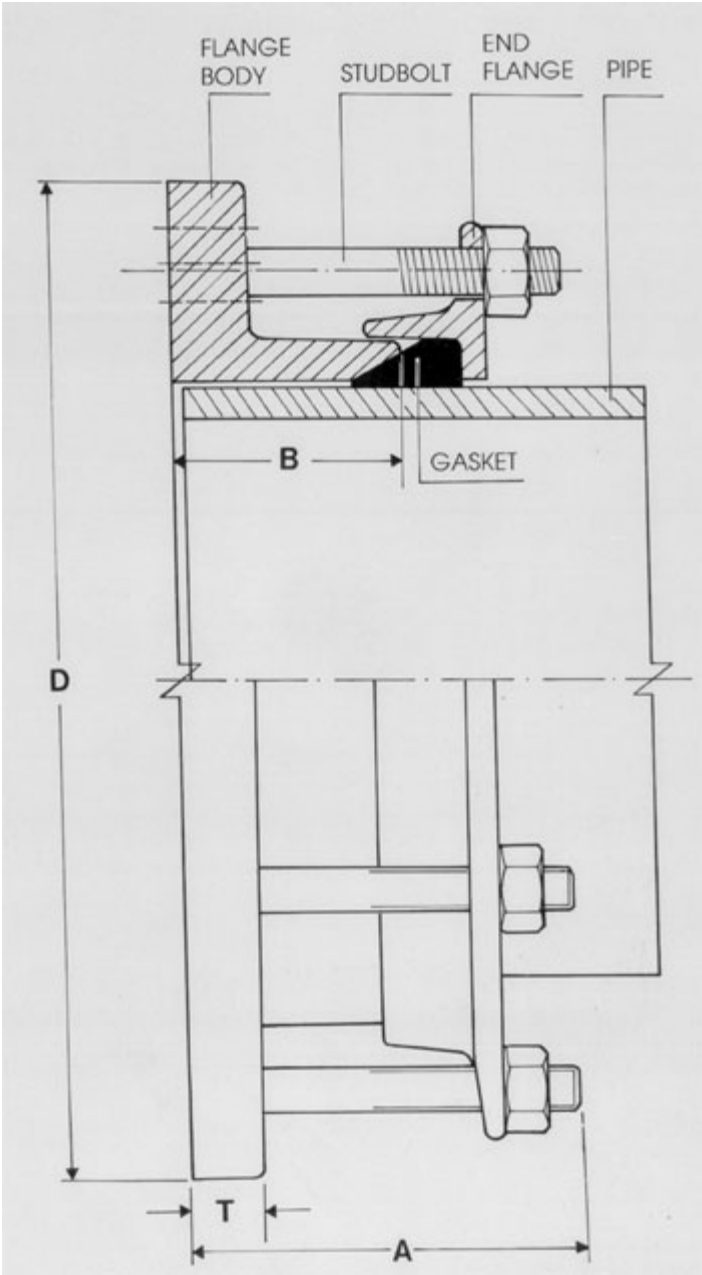

Pipemate Flange Adaptor

For Ductile Iron Pipe to BS 4772:1988/ISO 2531:1991

Flange Drilled to PN10 & PN16

Other drilling available on request.
All dimensions are in mm unless otherwise stated.

Pipe Dimensions			Flange Adaptor Dimensions										
Nom. Bore	Pipe OD	Flange Size	PN	D	T	A	B	No.	Boils Size	Hole ø	PCD k	No.	Studs Dia x lgth
80	98	80	10/16	200	20	118	75	8	M16	18	160	4	½" x 4½"
100	118	100	10/16	220	20	118	75	8	M16	18	180	4	½" x 4½"
150	170	150	10/16	285	22	118	75	8	M20	22	240	4	½" x 4½"
200	222	200	10	340	24	118	75	8	M20	22	295	4	½" x 4½"
			16	340	24	118	75	12	M20	22	295	6	½" x 4½"
250	274	250	10	395	25	136	90	12	M20	22	350	6	½" x 5¼"
			16	405	25	136	90	12	M24	26	355	6	½" x 5¼"
300	326	300	10	445	25	136	90	12	M20	22	400	6	½" x 5¼"
			16	460	25	136	90	12	M24	26	410	6	½" x 5¼"
350	378	350	10	505	25	155	105	16	M20	22	460	8	¾" x 6"
			16	520	25	155	105	16	M24	26	470	8	¾" x 6"
400	429	400	10	565	25	155	105	16	M24	26	515	8	¾" x 6"
			16	580	25	155	105	16	M27	30	525	8	¾" x 6"
450	480	450	10	615	25	155	105	20	M24	26	565	10	¾" x 6"
			16	640	25	155	105	20	M27	30	585	10	¾" x 6"
500	532	500	10	670	25	155	105	20	M24	26	620	10	¾" x 6"
			16	715	25	155	105	20	M30	33	650	10	¾" x 6"
600	635	600	10	780	25	155	105	20	M27	30	725	10	¾" x 6"
			16	840	25	155	105	20	M33	36	770	10	¾" x 6"
700	738	700	10	895	25	155	105	24	M27	30	840	12	¾" x 6"
			16	910	25	155	105	24	M33	36	840	12	¾" x 6"
800	842	800	10	1015	25	155	105	24	M30	33	950	12	¾" x 6"
			16	1025	25	155	105	24	M36	39	950	12	¾" x 6"
900	945	900	10	1115	25	155	115	28	M30	33	1050	14	¾" x 6"
			16	1125	25	155	115	28	M36	39	1050	14	¾" x 6"
1000	1048	1000	10	1230	25	155	115	28	M33	36	1160	14	¾" x 6"
			16	1255	25	155	115	28	M39	43	1170	14	¾" x 6"
1100	1152	1100	10	1340	38	180	125	32	M33	36	1270	16	¾" x 6½"
			16	1355	38	180	125	32	M39	43	1270	16	¾" x 6½"
1200	1255	1200	10	1455	38	180	125	32	M36	39	1380	16	¾" x 6½"
			16	1485	38	180	125	32	M45	48	1390	16	¾" x 6½"
1400	1462	1400	10	1675	38	180	125	36	M39	43	1590	18	¾" x 6½"
			16	1685	38	180	125	36	M45	49	1590	18	¾" x 6½"
1600	1668	1600	10	1915	60	275	185	40	M45	49	1820	40	¾" x 9"
			16	1930	60	275	185	40	M52	56	1820	40	¾" x 9"
1800	1875	1800	10	2115	60	275	185	44	M45	49	2020	44	¾" x 9"
			16	2130	60	275	185	44	M52	56	2020	44	¾" x 9"
2000	2082	2000	10	2325	60	275	185	48	M45	49	2230	48	¾" x 9"
			16	2345	60	275	185	48	M56	62	2230	48	¾" x 9"

Pipemate Flange Adaptor

For M.S. Pipes to BS534:1990; BS 3600:1976;

UPVC Pipe to BS 3505:1986

Flange Drilled to PN10 & PN16

Other drilling available on request.

All dimensions are in mm unless otherwise stated.

Pipe Dimensions				Flange Adaptor Dimensions									
Nom. Bore	Pipe OD	Flange Size	PN	D	T	A	B	No.	Bolts Size	Hole ø	PCD k	No.	Studs Dia x lgth
80	88.9	80	10/16	200	20	118	75	8	M16	18	160	4	½" x 4½"
100	114.3	100	10/16	220	20	118	75	8	M16	18	180	4	½" x 4½"
150	168.3	150	10/16	285	22	118	75	8	M20	22	240	4	½" x 4½"
200	219.1	200	10	340	24	118	75	8	M20	22	295	4	½" x 4½"
			16	340	24	118	75	12	M20	22	295	6	½" x 4½"
250	273.0	250	10	395	25	136	90	12	M20	22	350	6	½" x 5¼"
			16	405	25	136	90	12	M24	26	355	6	½" x 5¼"
300	323.9	300	10	445	25	136	90	12	M20	22	400	6	½" x 5¼"
			16	460	25	136	90	12	M24	26	410	6	½" x 5¼"
350	355.6	350	10	505	25	155	105	16	M20	22	460	8	¾" x 6"
			16	520	25	155	105	16	M24	26	470	8	¾" x 6"
400	406.4	400	10	565	25	155	105	16	M24	26	515	8	¾" x 6"
			16	580	25	155	105	16	M27	30	525	8	¾" x 6"
450	457.0	450	10	615	25	155	105	20	M24	26	565	10	¾" x 6"
			16	640	25	155	105	20	M27	30	585	10	¾" x 6"
500	508.0	500	10	670	25	155	105	20	M24	26	620	10	¾" x 6"
			16	715	25	155	105	20	M30	33	650	10	¾" x 6"
600	610.0	600	10	780	25	155	105	20	M27	30	725	10	¾" x 6"
			16	840	25	155	105	20	M33	36	770	10	¾" x 6"
700	711.0	700	10	895	25	155	105	24	M27	30	840	12	¾" x 6"
			16	910	25	155	105	24	M33	36	840	12	¾" x 6"
800	813.0	800	10	1015	25	155	105	24	M30	33	950	12	¾" x 6"
			16	1025	25	155	105	24	M36	39	950	12	¾" x 6"
900	914.0	900	10	1115	25	155	115	28	M30	33	1050	14	¾" x 6"
			16	1125	25	155	115	28	M36	39	1050	14	¾" x 6"
1000	1016.0	1000	10	1230	25	155	115	28	M33	36	1160	14	¾" x 6"
			16	1255	25	155	115	28	M39	43	1170	14	¾" x 6"
1100	1118.0	1100	10	1340	38	180	125	32	M33	36	1270	16	¾" x 6½"
			16	1355	38	180	125	32	M39	43	1270	16	¾" x 6½"
1200	1219.0	1200	10	1455	38	180	125	32	M36	39	1380	16	¾" x 6½"
			16	1485	38	180	125	32	M45	49	1390	16	¾" x 6½"
1400	1420.0	1400	10	1675	38	180	125	36	M39	43	1590	18	¾" x 6½"
			16	1685	38	180	125	36	M45	49	1590	18	¾" x 6½"
1600	1620.0	1600	10	1915	60	275	185	40	M45	49	1820	40	¾" x 9"
			16	1930	60	275	185	40	M52	56	1820	40	¾" x 9"
1800	1820.0	1800	10	2115	60	275	185	44	M45	49	2020	44	¾" x 9"
			16	2130	60	275	185	44	M52	56	2020	44	¾" x 9"
2000	2020.0	2000	10	2325	60	275	185	48	M45	49	2230	48	¾" x 9"
			16	2345	60	275	185	48	M56	62	2230	48	¾" x 9"

Pipemate Flange Adaptor

For Cast Iron Pipe to BS 78: 1981 and BS 1211: 1981

Flange Drilling to BS 10: 1962

Other drilling available on request.

All dimensions are in mm unless otherwise stated.

Pipe Dimensions				Flange Adaptor Dimensions									
Nom. Bore	Pipe OD	Flange Size	BS10 Table	D	T	A	B	No.	Bolts Size	Hole ø	PCD k	Studs No.	Dia x lgth
3'	96.0	3'	ADE	185	15	118	75	8	½"	18	146	4	½" x 4½"
4'	122.0	4'	ADE	216	17	118	75	8	½"	18	178	4	½" x 4½"
5'	150.0	5'	DE	254	17	118	75	8	½"	18	210	4	½" x 4½"
6'	177.8	6'	D	279	18	118	75	8	½"	18	235	4	½" x 4½"
			E	279	18	118	75	8	¾"	22	235	4	½" x 4½"
7'	205.0	7'	D	305	19	118	75	8	½"	18	260.5	4	½" x 4½"
			E	305	19	118	75	8	¾"	22	260.5	4	½" x 4½"
8'	232.0	8'	D	337	19	118	75	8	½"	18	292	4	½" x 4½"
			E	337	19	118	75	8	¾"	22	292	4	½" x 4½"
9'	259.0	9'	D	368	21	118	75	8	½"	18	324	4	½" x 4½"
			E	368	21	118	75	12	¾"	22	324	6	½" x 4½"
10'	286.0	10'	D	406	25	136	90	8	¾"	22	355.5	4	½" x 5¼"
			E	406	25	136	90	12	¾"	22	355.5	6	½" x 5¼"
12'	334.0	12'	D	457	25	136	90	12	¾"	22	406.5	6	½" x 5¼"
			E	457	25	136	90	12	¾"	25	406.5	6	½" x 5¼"
12'	345.0	12'	D	457	25	136	90	12	¾"	22	406.5	6	½" x 5¼"
			E	457	25	136	90	12	¾"	25	406.5	6	½" x 5¼"
14'	387.0 399.0	14'	DE	527	25	155	105	12	¾"	25	470	6	¾" x 6"
			DE	527	25	155	105	12	¾"	25	470	6	¾" x 6"
15'	413.0 426.0	15'	DE	552	25	155	105	12	¾"	25	494.5	6	¾" x 6"
			DE	552	25	155	105	12	¾"	25	494.5	6	¾" x 6"
16'	439.0 453.0	16'	ADE	577	25	155	105	12	¾"	25	520.5	6	¾" x 6"
			ADE	577	25	155	105	12	¾"	25	520.5	6	¾" x 6"
18'	492.0	18'	D	641	25	155	105	12	¾"	25	584	6	¾" x 6"
			E	641	25	155	105	16	¾"	25	584	8	¾" x 6"
18'	507.0	18'	D	641	25	155	105	12	¾"	25	584	6	¾" x 6"
			E	641	25	155	105	16	¾"	25	584	8	¾" x 6"
20'	545.0 560.0	20'	DE	705	25	155	105	16	¾"	25	641.5	8	¾" x 6"
			DE	705	25	155	105	16	¾"	25	641.5	8	¾" x 6"
21'	571.0	21'	D	737	25	155	105	16	¾"	25	673	8	¾" x 6"
			E	737	25	155	105	16	1"	29	673	8	¾" x 6"
21'	587.0	21'	D	737	25	155	105	16	¾"	25	673	8	¾" x 6"
			E	737	25	155	105	16	1"	29	673	8	¾" x 6"
24'	650.0	24'	D	826	25	155	105	16	1"	29	755.5	8	¾" x 6"
			E	826	25	155	105	16	1½"	32	755.5	8	¾" x 6"
24'	667.0	24'	D	826	25	155	105	16	1"	29	755.5	8	¾" x 6"
			E	826	25	155	105	16	1½"	32	755.5	8	¾" x 6"

Pipemate Flange Adaptor

For UPVC Pipe to BS 5556:1978 (1986)

Flange Drilled to PN10 & PN16

Other drilling available on request.
All dimensions are in mm unless otherwise stated.

Pipe Dimensions			Flange Adaptor Dimensions										
Nom. Bore	Pipe OD	Flange Size	PN	D	T	A	B	No.	Bolts Size	Hole ø	PCD k	Studs No.	Dia x lgth
63	63	50	10/16	165	18	118	75	4	M16	18	125	2	½" x 4½"
75	75	65	10/16	185	18	118	75	4	M16	18	145	2	½" x 4½"
90	90	80	10/16	200	20	118	75	8	M16	18	160	4	½" x 4½"
110	110	100	10/16	220	20	118	75	8	M16	18	180	4	½" x 4½"
125	125	125	10/16	250	22	118	75	8	M16	18	210	4	½" x 4½"
140	140	125	10/16	250	22	118	75	8	M16	18	210	4	½" x 4½"
160	160	150	10/16	285	22	118	75	8	M20	22	240	4	½" x 4½"
180	180	175	10/16	315	24	118	75	8	M20	22	270	4	½" x 4½"
200	200	200	10	340	24	118	75	8	M20	22	295	4	½" x 4½"
			16	340	24	118	75	12	M20	22	295	6	½" x 4½"
225	225	200	10	340	24	118	75	8	M20	22	295	4	½" x 4½"
			16	340	24	118	75	12	M20	22	295	6	½" x 4½"
250	250	250	10	395	25	136	90	12	M20	22	350	6	½" x 5¼"
			16	405	25	136	90	12	M24	26	355	6	½" x 5¼"
280	280	250	10	395	25	136	90	12	M20	22	350	6	½" x 5¼"
			16	405	25	136	90	12	M24	26	355	6	½" x 5¼"
315	315	300	10	445	25	136	90	12	M20	22	400	6	½" x 5¼"
			16	460	25	136	90	12	M24	26	410	6	½" x 5¼"
355	355	350	10	505	25	155	105	16	M20	22	460	8	¾" x 6"
			16	520	25	155	105	16	M24	26	470	8	¾" x 6"
400	400	400	10	565	25	155	105	16	M24	26	515	8	¾" x 6"
			16	580	25	155	105	16	M27	30	525	8	¾" x 6"
450	450	450	10	615	25	155	105	20	M24	26	565	10	¾" x 6"
			16	640	25	155	105	20	M27	30	585	10	¾" x 6"
500	500	500	10	670	25	155	105	20	M24	26	620	10	¾" x 6"
			16	715	25	155	105	20	M30	33	650	10	¾" x 6"

Pipemate Flange Adaptor

For Steel Pipe to JKR Standard (Malaysia)

Flange Drilled to PN10 & PN16

Other drilling available on request.

Notes: Length and Tolerance on pipes OD is to BS 534: 1990

All dimensions are in mm unless otherwise stated.

Pipe Dimensions								Flange Adaptor Dimensions					
Nom. Bore	Pipe OD	Flange Size	PN	D	T	A	B	No.	Bolts Size	Hole ø	PCD k	No.	Studs Dia x lgth
100	121.9	100	10/16	220	20	118	75	8	M16	18	180	4	½" x 4½"
150	177.3	150	10/16	285	22	118	75	8	M20	22	240	4	½" x 4½"
200	232.2	200	10	340	24	118	75	8	M20	22	295	4	½" x 4½"
				340	24	118	75	12	M20	22	295	6	½" x 4½"
250	286.0	250	10	395	25	136	90	12	M20	22	350	6	½" x 5½"
				405	25	136	90	12	M24	26	355	6	½" x 5½"
300	345.0	300	10	445	25	166	120	12	M20	22	400	6	½" x 6½"
				460	25	136	90	12	M24	26	410	6	½" x 5½"
350	399.3	350	10	505	25	210	160	16	M20	22	460	8	¾" x 8"
				520	25	155	105	16	M24	26	470	8	¾" x 6"
400	453.1	400	10	565	25	210	160	16	M24	26	515	8	¾" x 8"
				580	25	155	105	16	M27	30	525	8	¾" x 6"
450	507.0	450	10	615	25	210	160	20	M24	26	565	10	¾" x 8"
				640	25	155	105	20	M27	30	585	10	¾" x 6"
500	560.3	500	10	670	25	210	160	20	M24	26	620	10	¾" x 8"
				715	25	155	105	20	M30	33	650	10	¾" x 6"
600	667.0	600	10	780	25	210	160	20	M27	30	725	10	¾" x 8"
				840	25	155	105	20	M33	36	770	10	¾" x 6"
650	692.0	700	10	895	25	155	105	24	M27	30	840	12	¾" x 6"
				910	25	155	105	24	M33	36	840	12	¾" x 6"
700	754.0	700	10	895	25	155	105	24	M27	30	840	12	¾" x 6"
				910	25	155	105	24	M33	36	840	12	¾" x 6"
750	804.0	750	10	965	25	155	105	24	M30	33	900	12	¾" x 6"
				970	25	155	105	24	M33	36	900	12	¾" x 6"
800	854.0	800	10	1015	25	155	105	24	M30	33	950	12	¾" x 6"
				1025	25	155	105	24	M36	39	950	12	¾" x 6"
850	904.0	800	10	1015	25	235	185	24	M30	33	950	12	¾" x 9"
				1025	25	235	185	24	M36	39	950	12	¾" x 9"
900	954.0	900	10	1115	25	155	105	28	M30	33	1050	14	¾" x 6"
				1125	25	155	105	28	M36	39	1050	14	¾" x 6"
1000	1054.0	1000	10	1230	25	155	115	28	M33	36	1160	14	¾" x 6"
				1255	25	155	115	28	M39	43	1170	14	¾" x 6"
1100	1157.0	1100	10	1340	38	180	125	32	M33	36	1270	16	¾" x 6½"
				1355	38	180	125	32	M39	43	1270	16	¾" x 6½"
1200	1270.0	1200	10	1455	38	180	125	32	M36	39	1380	16	¾" x 6½"
				1485	38	180	125	32	M45	49	1390	16	¾" x 6½"
1400	1472.0	1400	10	1675	38	180	125	36	M39	43	1590	18	¾" x 6½"
				1685	38	180	125	36	M45	49	1590	18	¾" x 6½"

PIPEMATE STEPPED COUPLING

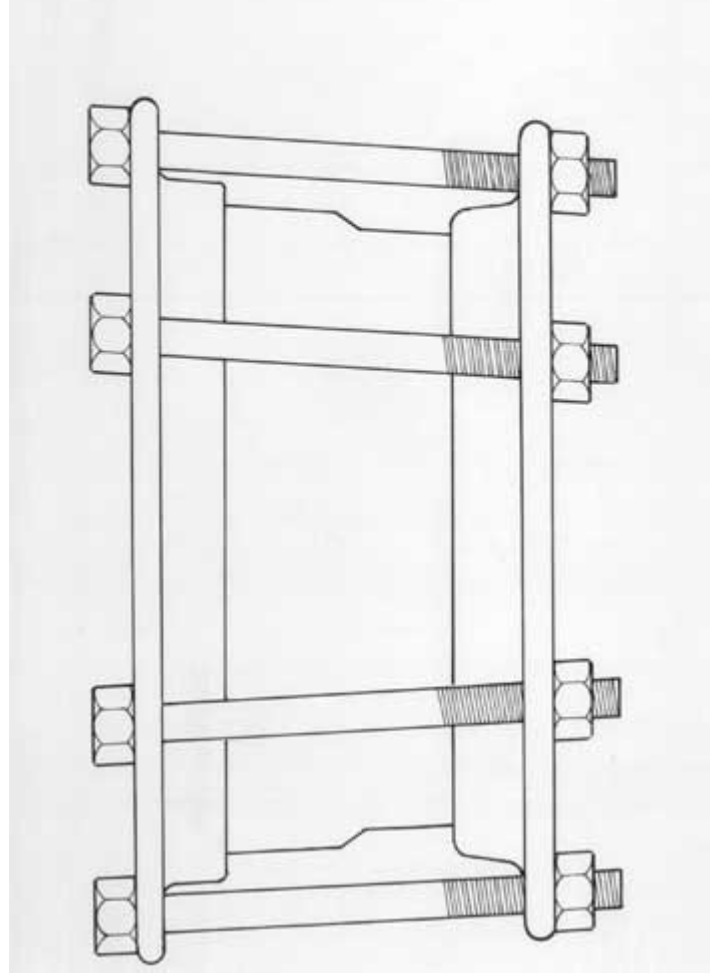

Pipemate Stepped Coupling

When joining pipes of different diameters, PIPEMATE Stepped Couplings offer many advantages.

These Stepped Couplings are fabricated from rolled steel in most common sizes and each with different wall thickness, depending on the internal pressure.

Pipemate Stepped Couplings can be supplied to connect pipes of different nominal bores or outside diameters – details on request.

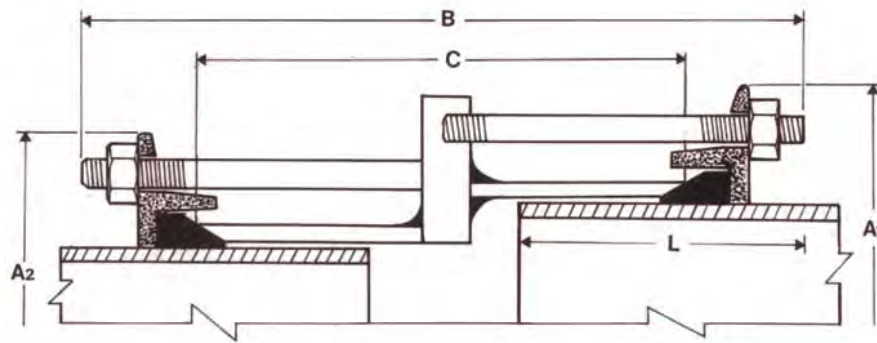
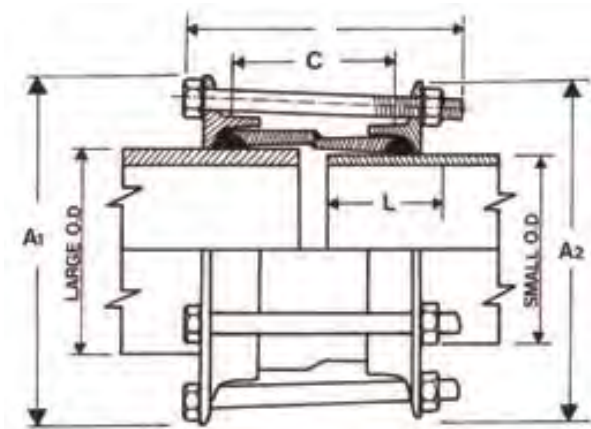

Pipemate Stepped Coupling

To Connect Ductile Iron Pipe to Steel Pipe

All dimensions are in mm unless otherwise stated.

These dimensions are indications, approximate and can be modified without prior notice.

Pipe Dimensions			Stepped Coupling Dimensions						
Nom. Bore	Pipe O.D		L	A ₁	A ₂	B	Sleeve C x Av thk	Bolts	
	D.I.	Steel						No.	Dia x lgth
80	98	88.9	100	198	190	175	100 x 6	4	½" x 6½"
100	118	114.3	100	220	218	175	100 x 6	4	½" x 6½"
150	170	168.3	100	272	270	175	100 x 7	4	½" x 6½"
200	222	219.3	100	326	324	175	100 x 8	5	½" x 6½"
250	274	273	100	379	377	175	100 x 8	6	½" x 6½"
300	326	323.9	100	430	426	175	100 x 8	6	½" x 6½"
350	378	355.6	150	482	460	228	150 x 8	8	¾" x 8½"
400	429	406.4	150	532	510	228	150 x 8	8	¾" x 8½"
450	480	457	150	584	562	228	150 x 8	8	¾" x 8½"
500	532	508	150	636	612	228	150 x 8	10	¾" x 8½"
600	635	610	150	738	716	228	150 x 8	12	¾" x 8½"
700	738	711	150	842	817	228	150 x 8	12	¾" x 8½"
800	842	813	150	946	920	228	150 x 8	14	¾" x 8½"
900	945	914	150	1050	1020	266	180 x 9	14	¾" x 10"
1000	1048	1016	150	1156	1126	266	180 x 9	14	¾" x 10"
1100	1152	1118	150	1276	1242	280	180 x 12	16	¾" x 10½"
1200	1255	1219	200	1380	1346	360	254 x 12	18	¾" x 13¼"
1400	1462	1420	200	1586	1546	360	254 x 12	20	¾" x 13¼"
1600	1668	1620	200	1792	1746	360	254 x 12	24	¾" x 13¼"

Pipemate Stepped Coupling
To Connect Ductile Iron Pipe
To Asbestos Cement/Cast Iron Pipe

All dimensions are in mm unless otherwise stated.

Pipe Dimensions			Stepped Coupling Dimensions						
Nom. Bore	Pipe O.D.		L	A ₁	A ₂	B	Sleeve C x Av thk	Bolts No.	Bolts Dia x lgth
	D.I.	AC/CI							
80	98	96	100	198	196	175	100 x 6	4	½" x 6½"
100	118	122	100	224	220	175	100 x 6	4	½" x 6½"
150	170	177.8	100	280	272	175	100 x 7	4	½" x 6½"
200	222	232	100	336	326	175	100 x 8	5	½" x 6½"
250	274	286	100	390	379	175	100 x 8	6	½" x 6½"
300	326	334	100	437	430	175	100 x 8	6	½" x 6½"
300	326	345	100	448	430	175	100 x 8	6	½" x 6½"
350	378	387	150	490	482	228	150 x 8	8	⅝" x 8½"
350	378	399	150	502	482	228	150 x 8	8	⅝" x 8½"
400	429	439	150	542	532	228	150 x 8	8	⅝" x 8½"
400	429	453	150	558	532	228	150 x 8	8	⅝" x 8½"
450	480	492	150	596	584	228	150 x 8	8	⅝" x 8½"
450	480	507	150	612	584	228	150 x 8	8	⅝" x 8½"
500	532	545	150	650	636	228	150 x 8	10	⅝" x 8½"
500	532	560	150	664	636	228	150 x 8	10	⅝" x 8½"
600	635	650	150	756	738	228	150 x 8	12	⅝" x 8½"
600	635	667	150	772	738	228	150 x 8	12	⅝" x 8½"

Pipemate Flange Restrained Dismantling Joint

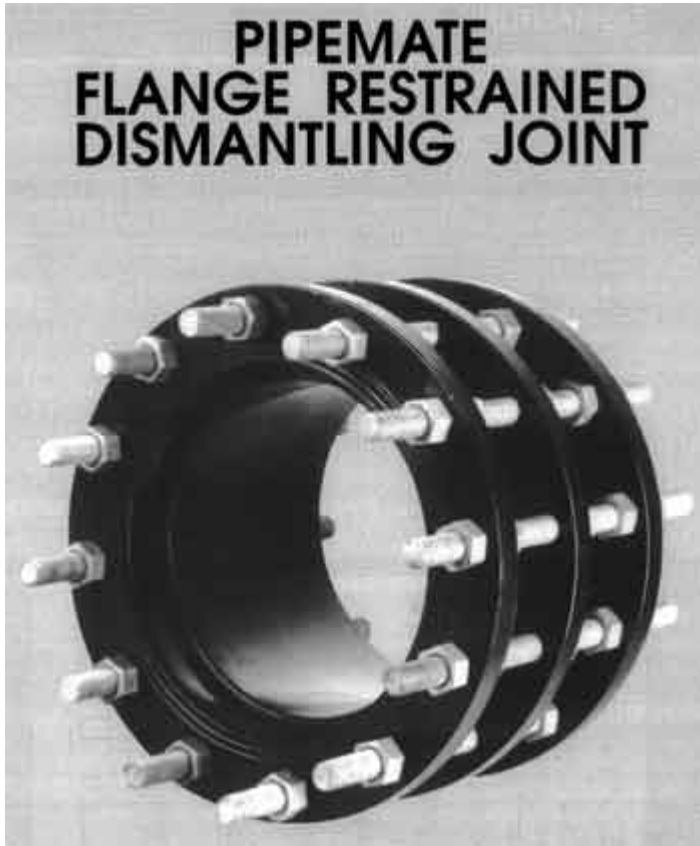

This joint consists of two flanged spigot pieces and a loose flange, one of which slides into the other flange spigot piece, and the loose flange which compresses the wedge-shaped rubber Sealing Rings. It is clamped by means of full thread tied studs.

Flange drillings can be made accordingly to all international standards and specifications.

These joints are available in welded steel as standard in the range from 50mm to 1600mm nominal diameter, must be installed above-ground and/or in a chamber.

Hot Dip Galvanized full thread tied studs c/w 5 nuts are supplied standard. Stainless steel tied studs are also available on request.

The standard coating is Fusion Bonded Epoxy (FBEP).

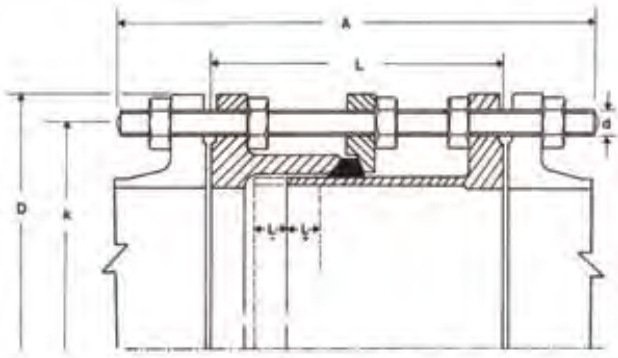

Pipemate Flange Restrained Dismantling Joint

Flange drilled to PN10, PN16 and PN25

Other drilling available on request.

All dimensions are in mm unless otherwise stated.

Pipe/Flange Nom. Bore	PN	Max L	Tol. L	D	K	Bolts		Studs Length (A)	
						No.	Hole ø		
50	10, 16, 25	200	± 25	165	125	4	18	16	310
80	10, 16, 25	200	± 25	200	160	8	18	16	310
100	10, 16, 25	220	± 25	220	180	8	18	16	340
150	10, 16 25	220	± 25	285	240	8	22	20	340
		230	± 25	300	250	8	26	24	370
200	10	250	± 25	340	295	8	22	20	410
	16	250	± 25	340	295	12	22	20	410
	25	250	± 25	360	310	12	26	24	410
250	10	250	± 25	395	350	12	22	20	410
	16	250	± 25	405	355	12	26	24	410
	25	250	± 25	425	370	12	30	27	410
300	10	250	± 25	445	400	12	22	20	410
	16	250	± 25	460	410	12	26	24	410
	25	250	± 25	485	430	16	30	27	410
350	10	260	± 25	505	460	16	22	20	410
	16	260	± 25	520	470	16	26	24	410
	25	300	± 25	555	490	16	33	30	460
400	10	300	± 25	565	515	16	26	24	460
	16	300	± 25	580	525	16	30	27	460
	25	300	± 25	620	550	16	36	33	500
450	10	300	± 25	615	565	20	26	24	460
	16	300	± 25	640	585	20	30	27	460
	25	300	± 25	670	600	20	36	33	500
500	10	300	± 25	670	620	20	26	24	460
	16	300	± 25	715	650	20	33	30	460
	25	320	± 25	730	660	20	36	33	500
600	10	320	± 25	780	725	20	30	27	480
	16	320	± 25	840	770	20	36	33	520
	25	340	± 25	845	770	20	39	36	540
700	10	320	± 25	895	840	24	30	27	480
	16	320	± 25	910	840	24	36	33	520
	25	380	± 25	960	875	24	42	39	580
800	10	340	± 25	1015	950	24	33	30	520
	16	340	± 25	1025	950	24	39	36	540
	25	380	± 25	1085	990	24	48	45	620
900	10	340	± 25	1115	1050	28	33	30	520
	16	340	± 25	1125	1050	28	39	36	540
	25	380	± 25	1185	1090	28	48	45	620
1000	10	360	± 25	1230	1160	28	36	33	550
	16	360	± 25	1255	1170	28	42	39	580
	25	400	± 25	1320	1210	28	56	52	660
1100	10	360	± 25	1340	1270	32	36	33	550
	16	360	± 25	1355	1270	32	42	39	580
1200	10	360	± 25	1455	1380	32	39	36	580
	16	380	± 25	1485	1390	32	48	45	620
	25	450	± 25	1530	1420	32	56	52	750

Pipemate Flange Restrained Dismantling Joint

Flange drilled to PN10, PN16 and PN25

Other drilling available on request.

All dimensions are in mm unless otherwise stated.

Pipe/Flange Nom. Bore	PN	Max L	Tol. L	D	K	Bolts		Studs	
						No.	Hole ϕ	Size (d)	Length (A)
1300	10	380	± 25	1575	1490	32	42	39	620
	16	380	± 25	1585	1490	32	48	45	620
1400	10	380	± 25	1675	1590	36	42	39	600
	16	380	± 25	1685	1590	36	48	45	630
1500	10	400	± 25	1785	1700	36	42	39	620
1600	10	400	± 25	1915	1820	40	48	45	630

Flange Mating Dimensions

BS 10: 1962

ANSI B16.5: 1981

DN: Nominal diameter

D: Flange diameter

K: Diameter of bolt circle

L: Diameter of bolt hole

M: Bolt size

N: Number of bolt hole

(All dimensions in mm)

DN	BS.10 : 1962					ANSI B16.5 : 1981									
	TABLE E					PN 20 (CLASS 150)					PN 50 (CLASS 300)				
	D	K	L	M	N	D	K	L	M	N	D	K	L	M	N
50	152	114	18	M16	4	150	120.5	20	M18	4	165	127.0	20	M18	8
65	165	127	18	M16	4	180	139.5	20	M18	4	190	149.0	22	M20	8
80	185	146	18	M16	4	190	152.5	20	M18	4	210	168.5	22	M20	8
100	216	178	18	M16	8	230	190.5	20	M18	8	255	200.0	22	M20	8
125	254	210	18	M16	8	255	216.0	22	M20	8	280	235.0	22	M20	8
150	279	235	22	M20	8	280	241.5	22	M20	8	320	270.0	22	M20	12
200	337	292	22	M20	8	345	298.5	22	M20	8	380	330.0	26	M24	12
250	406	355	22	M20	12	405	362.0	26	M24	12	445	387.5	30	M27	16
300	457	406	26	M24	12	485	432.0	26	M24	12	520	451.0	33	M30	16
350	527	470	26	M24	12	535	476.0	30	M27	12	585	514.5	33	M30	20
400	580	521	26	M24	12	600	540.0	30	M27	16	650	571.5	36	M33	20
450	641	584	26	M24	16	635	578.0	33	M30	16	715	682.5	36	M33	24
500	705	641	26	M24	16	700	635.0	33	M30	20	775	686.0	36	M33	24
600	826	756	33	M30	16	815	749.5	36	M33	20	915	813.0	42	M39	24

Flange Mating Dimensions

BS. 4504: Section 3.1: 1989

DN: Nominal diameter

D: Flange diameter

K: Diameter of bolt circle

L: Diameter of bolt hole

M: Bolt size

N: Number of bolt hole

(All dimensions in mm)

DN	PN 6					PN 10					PN 16				
	D	K	L	M	N	D	K	L	M	N	D	K	L	M	N
50	140	110	14	M12	4	165	125	18	M16	4	165	125	18	M16	4
65	160	130	14	M12	4	185	145	18	M16	4	185	145	18	M16	4
80	190	145	18	M16	4	200	160	18	M16	8	200	160	18	M16	8
100	210	170	18	M16	4	220	180	18	M16	8	220	180	18	M16	8
125	240	200	18	M16	8	250	210	18	M16	8	250	210	18	M16	8
150	265	225	18	M16	8	285	240	22	M20	8	285	240	22	M20	8
200	320	280	18	M16	8	340	295	22	M20	8	340	295	22	M20	12
250	375	335	18	M16	12	395	350	22	M20	12	405	355	26	M24	12
300	440	395	22	M20	12	445	400	22	M20	12	460	410	26	M24	12
350	490	445	22	M20	12	505	460	22	M20	16	520	470	26	M24	16
400	540	495	22	M20	16	565	515	26	M24	16	580	525	30	M27	16
450	595	550	22	M20	16	615	565	26	M24	20	640	585	30	M27	20
500	645	600	22	M20	20	670	620	26	M24	20	715	650	33	M30	20
600	755	705	26	M24	20	780	725	30	M27	20	840	770	36	M33	20
700	860	810	26	M24	24	895	840	30	M27	24	910	840	36	M33	24
800	975	920	30	M27	24	1015	950	33	M30	24	1025	950	39	M36	24
900	1075	1020	30	M27	24	1115	1050	33	M30	28	1125	1050	39	M36	28
1000	1175	1130	30	M27	28	1230	1160	36	M33	28	1255	1170	42	M39	28
1200	1405	1340	33	M30	32	1455	1380	39	M36	32	1485	1390	48	M45	32
1400	1630	1560	36	M33	36	1675	1590	42	M39	36	1685	1590	48	M45	36
1600	1830	1760	36	M33	40	1915	1820	48	M45	40	1930	1820	56	M52	40
1800	2045	1970	39	M36	44	2115	2020	48	M45	44	2130	2020	56	M52	44
2000	2265	2180	42	M39	48	2325	2230	48	M45	48	2345	2230	62	M56	48

Flange Mating Dimensions

JIS B 2210 = 1984

DN: Nominal diameter

D: Flange diameter

K: Diameter of bolt circle

L: Diameter of bolt hole

M: Bolt size

N: Number of bolt hole

(All dimensions in mm)

DN	JIS 5K					JIS 10K					JIS 16K				
	D	K	L	M	N	D	K	L	M	N	D	K	L	M	N
50	130	105	15	M12	4	155	120	19	M16	4	155	120	19	M16	8
65	155	130	15	M12	4	175	140	19	M16	4	175	140	19	M16	8
80	180	145	19	M16	4	185	150	19	M16	8	200	160	23	M20	8
100	200	165	19	M16	8	210	175	19	M16	8	225	185	23	M20	8
125	235	200	19	M16	8	250	210	23	M20	8	270	225	25	M22	8
150	265	230	19	M16	8	280	240	23	M20	8	305	260	25	M22	12
200	320	280	23	M20	8	330	290	23	M20	12	350	305	25	M22	12
250	385	345	23	M20	12	400	355	25	M22	12	430	380	27	M24	12
300	430	390	23	M20	12	445	400	25	M22	16	480	430	27	M24	16
350	480	435	25	M22	12	490	445	25	M22	16	540	480	33	M30	16
400	540	495	25	M22	16	560	510	27	M24	16	605	540	33	M30	16
450	605	555	25	M22	16	620	565	27	M24	20	675	605	33	M30	20
500	655	605	25	M22	20	675	620	27	M24	20	730	660	33	M30	20
600	770	715	27	M24	20	795	730	33	M30	24	845	770	39	M36	24
700	875	820	27	M24	24	905	840	33	M30	24	960	875	42	M39	24
800	995	930	33	M30	24	1020	950	33	M30	28	1085	990	48	M45	24
900	1095	1030	33	M30	24	1120	1050	33	M30	28	1185	1090	48	M45	28
1000	1195	1130	33	M30	28	1235	1160	39	M36	28	1320	1210	56	M52	28
1100	1305	1240	33	M30	28	1345	1270	39	M36	28	1420	1310	56	M52	32
1200	1420	1350	33	M30	32	1465	1380	39	M36	32	1530	1420	56	M52	32