



**PEPEMATE**



**PEGRIP™**



# PEGRIP™ RESTRAINT COUPLING & ADAPTOR

FOR PE PIPES, DN 63 TO DN 315  
UP TO PN 16 FOR WATERWORKS  
FUSION BONDED EPOXY (FBE) COATED

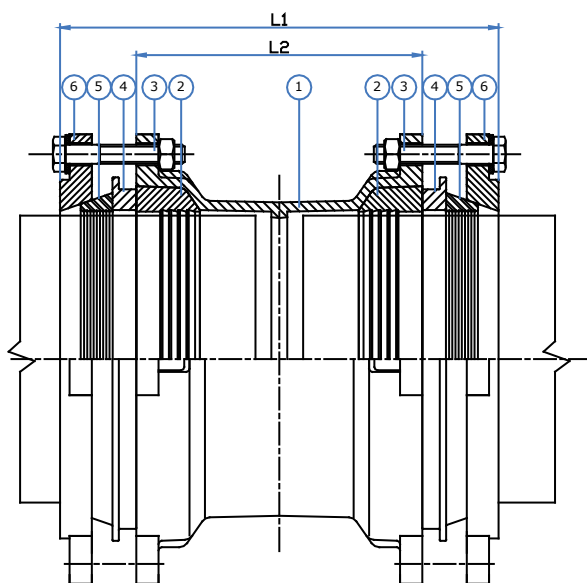

**PEGRIP COUPLING**

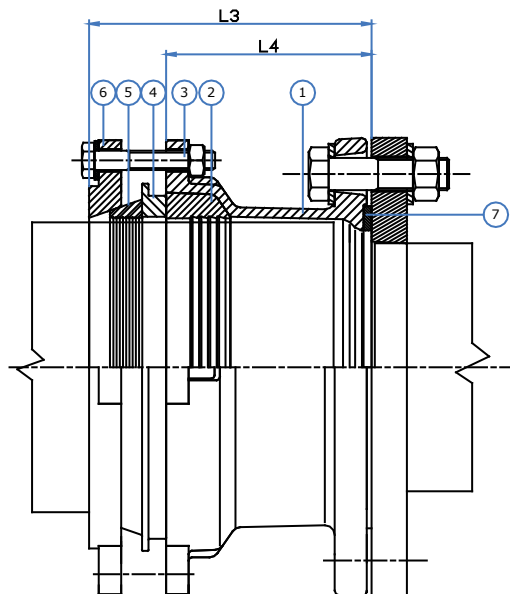

**PEGRIP FLANGE ADAPTOR**

- ◆ Easy to install, dismantle and maintain in all weather conditions.
- ◆ Provide total restraint.
- ◆ No special tool or equipment required.
- ◆ Corrosion protection with Fusion Bonded Epoxy (FBE) Coating.

PEGRIP COUPLING				PEGRIP FLANGE ADAPTOR				FLANGE INFOR.			
SIZE DN	L1	L2	BOLTS DIA x NO	FLANGE DN	L3	L4	BOLTS DIA x NO	PN 10/16	TABLE D	TABLE E	ANSI 150
63	214	130	M12 X 6	80	107	65	M12 X 3	*			*
90	232	140	M12 X 6	80	115	70	M12 X 3	*			*
110	241	146	M12 X 6	100	120	73	M12 X 3	*	*	*	*
125	245	150	M12 X 6	100	158	110	M12 X 3	*	*	*	*
160	272	174	M12 X 8	150	138	90	M12 X 4	*			*
180	282	180	M12 X 8	150	176	125	M12 X 4	*			*
225	309	200	M12 X 10	200	185	125	M12 X 5	*	*	*	*
250	323	200	M12 X 10	250	192	130	M12 X 5	*		*	*
280	332	200	M12 X 10	250	206	140	M12 X 5	*		*	*
315	348	210	M12 X 16	300	219	150	M12 X 8	*			*

No	Component	Material
1	Body	Ductile Iron, BS EN 1563 Grade 450/10
2	Gasket	EPDM, BS EN 681-1 Type WA
3	Bolts / Nuts	SS, ANSI 304 Grade A2-70 / St Gr 8.8 Decromat Coated
4	Intermediate Ring	Ductile Iron, BS EN 1563 Grade 450/10
5	Grip Ring	MS 58 (Dezincification Resistant Brass) Rg7 for DN315 only.
6	End Ring	Ductile Iron, BS EN 1563 Grade 450/10
7	Flange Gasket	EPDM, BS EN 681-1 Type WA

SERVICE CONDITIONS	
Service Temperature Range	-20° C to 70° C
Maximum Working Pressure	16 bars

## PIPEMATE SDN BHD (106977-A)

No 28 (Lot 17512) Jalan Dua, Kws Perindustrian Selayang  
Taman Selayang Baru, 68100 Selangor D.E., Malaysia  
Tel: 603-61380977, 61388667, 61387211  
Fax: 603-61388772 email: [pipemate@tm.net.my](mailto:pipemate@tm.net.my)

All information in this brochure was correct to the best of our knowledge when originally printed. Pipemate reserves the right to make changes without notice to product specifications and manufacture processes given the company's policy of continual product improvement.