



# PIPEMATE SURFACE BOX AND ACCESSORIES FOR UNDERGROUND GATE VALVE

## SURFACE BOX

Main component & material

NO	NAME	MATERIAL
1	Cover	Ductile Iron
2	Fastener	Stainless Steel
3	Nut	Stainless Steel + Nylon
4	Yoke	ABS
5	Buffer washer	Stainless Steel

Dimensions

SUITABLE VALVE SIZE	D1	□F	L	n-d
DN 80-300	272	□188	270	3-10

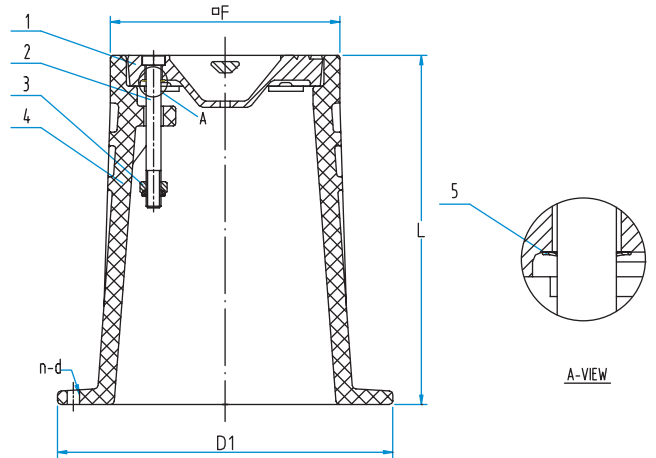

## TELESCOPIC EXTENSION SPINDLE

Main component & material

NO	NAME	MATERIAL
6	Extension Spindle	WCB
7	Protection tube	PP
8	Square stem	Q 235

Dimensions

SUITABLE VALVE SIZE	H1	H2	□C	D
DN 80-300	580	860	□25	70

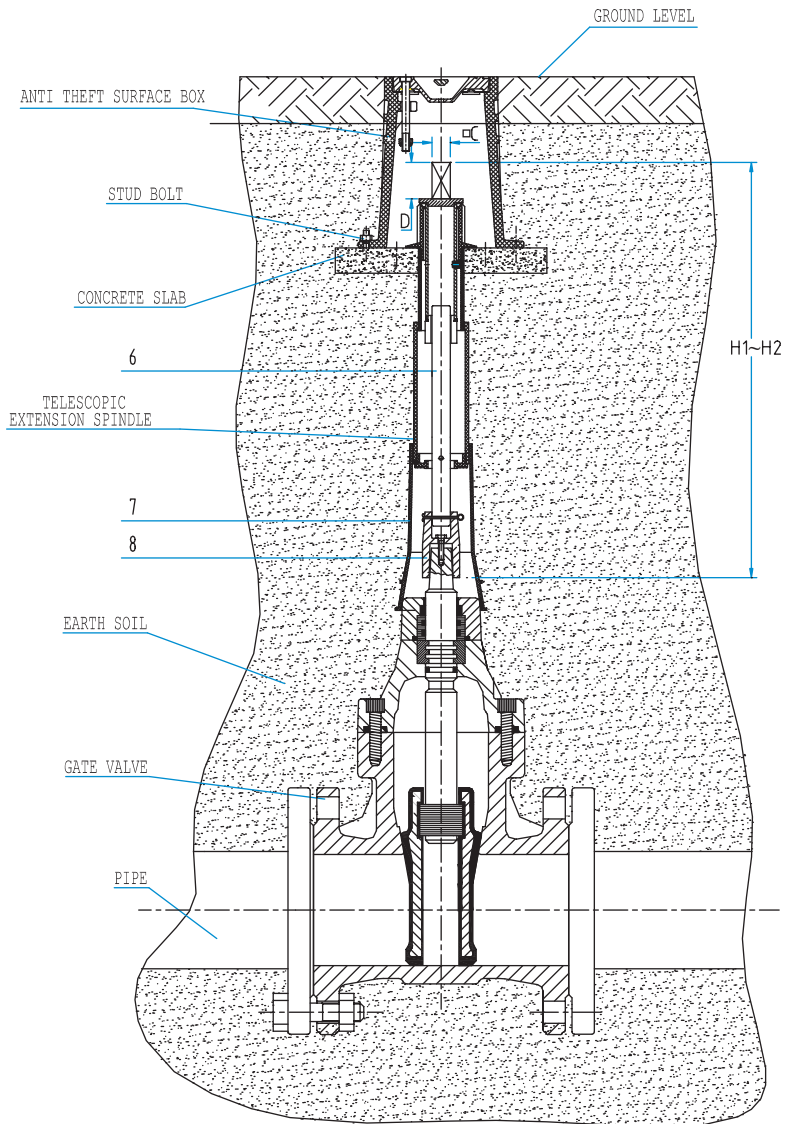

## PIPEMATE SDN BHD (106977-A)

No 28 (Lot 17512) Jalan Dua, Kws Perindustrian Selayang  
Taman Selayang Baru, 68100 Selangor D.E., Malaysia  
Tel: 603-61380977, 61388667, 61387211  
Fax: 603-61388772 email: [pipemate@tm.net.my](mailto:pipemate@tm.net.my)

All information in this brochure was correct to the best of our knowledge when originally printed. Pipemate reserves the right to make changes without notice to product specifications and manufacture processes given the company's policy of continual product improvement.