

PIPEMATE RESILIENT WEDGE GATE VALVE

PN 10 OR PN 16, 450 MM TO 600 MM (c/w BY-PASS VALVE)
 TO BS 5163 : 1986 TYPE B, STEM SEALING REPLACEABLE UNDER PRESSURE
 FUSION BONDED EPOXY (FBE) COATED

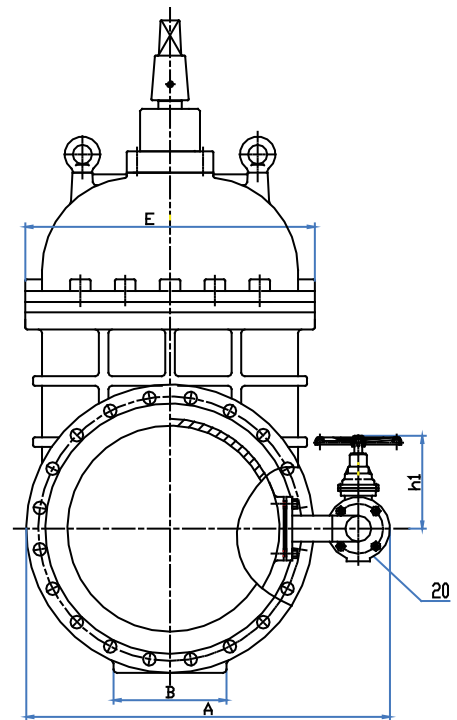
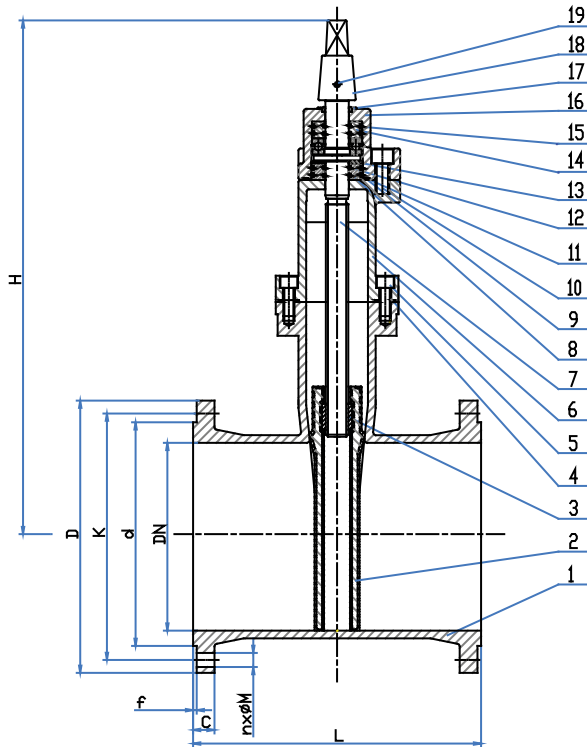

APPLICABLE STANDARDS	
Face to Face Dimension	BS 5163-PN 25/ISO 5752-Series 15
Flange Drillings	BS EN 1092-2/ISO 7005 PN 10 or PN 16, other drilling available

TESTS	
Test	Hydraulic tested to BS 5163 Body Test 1.5 x Maximum Working Pressure Seat Test 1.1 x Maximum Working Pressure Operating Torque Test.

FEATURES	
Operating Stem	12 mm lead
Direction of Closing	Clockwise closing unless otherwise specified

SERVICE CONDITIONS	
Maximum Service Temperature	80° C
Maximum Working Pressure	10 bars or 16 bars

No	Component	Material
1	Valve Body	Ductile Iron, BS EN 1563 Grade 500/7
2	Resilient Wedge	Ductile Iron, BS EN 1563 Grade 500/7 Fully Encapsulated with NBR or EPDM, BS EN 681-1 Type WA
3	Stem Nut	Gunmetal, BS 1400 LG2
4	Bonnet Gasket	EPDM, BS EN 681-1 Type WA
5	Bonnet Bolt	Zinc Coated Steel/S.S., BS 970 Part 1 304S31
6	Bonnet	Ductile Iron, BS EN 1563 Grade 500/7
7	Stem	Stainless Steel, BS 970:Part 1 431S29
8	Guiding Bushing	Gunmetal, BS1400 LG2
9	O Ring	EPDM, BS EN 681-1 Type WA
10	Gland Bolt	Zinc Coated Steel/S.S., BS 970 Part 1 304S31
11	O Ring	EPDM, BS EN 681-1 Type WA
12	O Ring	EPDM, BS EN 681-1 Type WA
13	Stem Gasket	PTFE
14	O Ring Retaining Ring	AL Bronze
15	O Ring	EPDM, BS EN 681-1 Type WA
16	Gland	Ductile Iron, BS EN 1563 Grade 500/7
17	Dust Prevention Cover	NBR, BS EN 681-1 Type WA
18	Stem Cap	Ductile Iron, BS EN1563 Grade 500/7
19	Stem Cap Screw	Stainless Steel, BS 970 Part 1 SS 304
20	By-Pass Valve	Ductile Iron, BS EN 1563 Grade 420/12

DIMENSIONS 'mm'

DN	E	L	H	H1	A	B	f	PN 10					PN 16					BY-PASS VALVE
								D	K	d1	C	n x ØM	D	K	d1	C	n x ØM	
450	510	650	1144	260	859	235	4	615	565	530	25.5	20 x 28	640	585	548	30	20 x 31	DN 50
500	630	700	1240	260	937	240	4	670	620	582	26.5	20 x 28	715	650	609	31.5	20 x 34	DN 50
600	795	800	1436	270	1072	330	5	780	725	682	30	20 x 31	840	770	720	36	20 x 37	DN 80

PIPEMATE SDN BHD (106977-A)

No 28 (Lot 17512) Jalan Dua, Kws Perindustrian Selayang
 Taman Selayang Baru, 68100 Selangor D.E., Malaysia
 Tel: 603-61380977, 61388667, 61387211
 Fax: 603-61388772 email: pipemate@tm.net.my

All information in this brochure was correct to the best of our knowledge when originally printed. Pipemate reserves the right to make changes without notice to product specifications and manufacture processes given the company's policy of continual product improvement.